

**INCAS - National Institute for Aerospace Research "Elie Carafoli"  
(under the aegis of The Romanian Academy)**

# **AEROSPATIAL 2010**



**Proceedings  
of the International Conference of Aerospace Sciences  
"AEROSPATIAL 2010"  
20 - 21 October, 2010  
Bucharest, Romania**

**BUCHAREST  
2010**

**Proceedings**  
**of the International Conference of Aerospace Sciences**  
**“AEROSPATIAL 2010”**  
**20 - 21 October, 2010**  
**Bucharest, Romania**

**SECTIONS**

1. Aerodynamics
2. Flight Mechanics and Systems Integration
3. Astronautics and Astrophysics
4. Materials and Structures
5. Systems, Subsystems and Control
6. Experimental investigations in aerospace science
7. Management in aerospace activities

More information of the conference “AEROSPATIAL 2010” at web address:  
[http://mail.incas.ro/AEROSPATIAL\\_2010/index.html](http://mail.incas.ro/AEROSPATIAL_2010/index.html)

**Editing:** Elena NEBANCEA – National Institute for Aerospace Research “Elie Carafoli”

**AEROSPATIAL 2010**

<b>Publisher:</b>	<b>INCAS – National Institute for Aerospace Research “Elie Carafoli”</b> Copyright © INCAS, 2010. All rights reserved.
<b>Registration code:</b>	<b>ISSN 2067 – 8614</b> <b>ISSN National Center</b> <b>Romanian National Library</b>

**INCAS – NATIONAL INSTITUTE FOR AEROSPACE RESEARCH “ELIE CARAFOLI”**  
Bucharest Iuliu Maniu St. no. 220, sector 6, O.P. 76, Code 061126  
Phone: +4021 4340083, Fax: +4021 4340082  
E-mail: [incas@incas.ro](mailto:incas@incas.ro), <http://www.incas.ro>

**INCAS – National Institute for Aerospace Research “Elie Carafoli”  
(under the Aegis of Romanian Academy)**

# **AEROSPATIAL 2010**

**Proceedings  
of the International Conference of Aerospace Sciences  
“AEROSPATIAL 2010”  
20 - 21 October, 2010  
Bucharest, Romania**

**BUCHAREST  
2010**

Copyright © INCAS, 2010. All rights reserved.

# International Conference of Aerospace Sciences

## "AEROSPATIAL 2010"

Bucharest, 20-21 October, 2010

### GRAPHIC PROGRAM

Hour	20 October 2010			Hour	21 October 2010	
8. <sup>00</sup> - 9. <sup>00</sup>	REGISTRATION Coffee Break			9. <sup>00</sup> - 10. <sup>00</sup>	REGISTRATION Coffee Break	
9. <sup>00</sup> -9. <sup>30</sup>	OPENING SESSIONS			10. <sup>00</sup> -10. <sup>20</sup>	Plenary Session	
10. <sup>00</sup> -10. <sup>20</sup>	Plenary Session					
10. <sup>40</sup> -11. <sup>00</sup>	S1.1.1	S2.1.1	S5.1.1	10. <sup>40</sup> -11. <sup>00</sup>	S4.2.1	S7.1.1
11. <sup>00</sup> -11. <sup>20</sup>	S1.1.2	S2.1.2	S5.1.2	11. <sup>00</sup> -11. <sup>20</sup>	S4.2.2	S7.1.2
11. <sup>20</sup> -11. <sup>40</sup>	S1.1.3	S2.1.3	S5.1.3	11. <sup>20</sup> -11. <sup>40</sup>	S4.2.3	S7.1.3
11. <sup>40</sup> -12. <sup>00</sup>	S1.1.4	S2.1.4	S5.1.4	11. <sup>40</sup> -12. <sup>00</sup>	S4.2.4	S7.1.4
12. <sup>00</sup> -12. <sup>20</sup>	S1.1.5	S2.1.5	S5.1.5	12. <sup>00</sup> -12. <sup>20</sup>	S4.2.5	S7.1.5
12. <sup>20</sup> -12. <sup>40</sup>	S1.1.6	S2.1.6	S5.1.6	12. <sup>20</sup> -12. <sup>40</sup>	S4.2.6	S7.1.6
12. <sup>40</sup> -13. <sup>00</sup>	S1.1.7	S2.1.7	S5.1.7	12. <sup>40</sup> -13. <sup>00</sup>	S4.2.7	S7.1.7
13. <sup>00</sup> -14. <sup>00</sup>	Lunch			13. <sup>00</sup> -14. <sup>00</sup>	Lunch	
14. <sup>00</sup> -14. <sup>20</sup>	S1.2.1	S2.2.1	S5.2.1	14. <sup>00</sup> -14. <sup>20</sup>	S4.3.1	S7.2.1
14. <sup>20</sup> -14. <sup>40</sup>	S1.2.2	S2.2.2	S5.2.2	14. <sup>20</sup> -14. <sup>40</sup>	S4.3.2	S7.2.2
14. <sup>40</sup> -15. <sup>00</sup>	S1.2.3	S2.2.3	S5.2.3	14. <sup>40</sup> -15. <sup>00</sup>	S4.3.3	S7.2.3
15. <sup>00</sup> -15. <sup>20</sup>	S1.2.4	S4.1.1	S5.2.4	15. <sup>00</sup> -15. <sup>20</sup>	S4.3.4	S7.2.4
15. <sup>20</sup> -15. <sup>40</sup>	S1.2.5	S4.1.2	S5.2.5	15. <sup>20</sup> -15. <sup>40</sup>		S7.2.5
15. <sup>40</sup> -16. <sup>00</sup>	S1.2.6	S4.1.3	S5.2.6	15. <sup>40</sup> -16. <sup>00</sup>		S7.2.6
16. <sup>00</sup> -16. <sup>20</sup>	Coffee Break			16. <sup>00</sup> -16. <sup>20</sup>		S7.2.7
16. <sup>20</sup> -16. <sup>40</sup>	S1.2.7	S4.1.4	S6.1.1	CLOSING SESSIONS		
16. <sup>40</sup> -17. <sup>00</sup>	S1.2.8	S4.1.5	S6.1.2			
17. <sup>00</sup> -17. <sup>20</sup>	S1.2.9	S4.1.6	S6.1.3			
17. <sup>20</sup> -17. <sup>40</sup>	S1.2.10	S4.1.7	S6.1.4			
17. <sup>40</sup> -18. <sup>00</sup>	S1.2.11	S4.1.8	S6.1.5			
18. <sup>00</sup> -18. <sup>20</sup>	S1.2.12	S4.1.9	S6.1.6			
18. <sup>20</sup> -18. <sup>40</sup>	S3.1.1	S4.1.10	S6.1.7			
18. <sup>40</sup> -19. <sup>00</sup>	S3.1.2	S4.1.11	S6.1.8			
19. <sup>00</sup> -19. <sup>20</sup>	S3.1.3	S4.1.12	S6.1.9			
19. <sup>30</sup>	DINNER					

- S1 - Section 1. Aerodynamics
- S2 - Section 2. Flight Mechanics and Systems Integration
- S3 - Section 3. Astronautics and Astrophysics
- S4 - Section 4. Materials and Structures
- S5 - Section 5. Systems, Subsystems and Control
- S6 - Section 6. Experimental investigations in aerospace sciences
- S7 - Section 7. Management in aerospace activities

- "ELIE CARAFOLI" Amphitheatre
- "Nicolae TIPEI" Amphitheatre
- "Alexe MARINESCU" Amphitheatre, Building block B, First Floor

The works are published in the volume into sections, in order of their presentation at the conference.



## CONTENTS

<b>SECTION 1. Aerodynamics</b>	<b>1</b>
❖ <b>Evolutionary, iterative optimum-optimorum theory</b> Adriana NASTASE	<b>3</b>
❖ <b>Prediction of ice shapes and effects of roughness on aerodynamic performance</b> Maria ALEXANDRESCU, Nicușor ALEXANDRESCU	<b>10</b>
❖ <b>An improved analytical solution for 2D inviscid incompressible flow through a channel with wall fluid injection and wall regression</b> Corneliu BERBENTE, Sterian DĂNĂILĂ, Sorin BERBENTE	<b>19</b>
❖ <b>An analytical model for inviscid incompressible flow around lifting surfaces of any shape</b> Marius BREBENEL	<b>27</b>
❖ <b>The rotational velocities evaluation for the engine mounts gyroscopic loads</b> Ștefan BOGOS	<b>39</b>
❖ <b>A vortex method approach to study the flow about flapping wings</b> Valentin BUTOESCU, Andrei CRĂIFĂLEANU, Ștefan NEBANŢEA	<b>47</b>
❖ <b>Numerical investigation of the free boundary flow past an obstacle</b> Adrian CARABINEANU, Ștefan Gicu CRUCEANU	<b>59</b>
❖ <b>On the use of lattice Boltzmann methods for reduced order modeling of bluff body aerodynamics</b> Marius-Gabriel COJOCARU, Claudiu-Cristian VĂDEAN	<b>70</b>
❖ <b>An improved BEM model for the power prediction of vertical axis wind turbines</b> Radu BOGĂȚEANU, Horia DUMITRESCU, Vladimir CARDOȘ	<b>80</b>
❖ <b>Computational studies of the effects of turbulent wall jet over a curved surface</b> Florin FRUNZULICĂ, Alexandru DUMITRACHE, Horia DUMITRESCU, Vladimir CARDOȘ	<b>90</b>
❖ <b>In-flight ice accretion prediction code</b> Vladimir HORÁK, Zdeněk CHÁRA	<b>97</b>
❖ <b>Analysis of low-Reynolds-number flows past airfoils</b> Dan MATEESCU	<b>105</b>
❖ <b>Simulation of wake vortex aircraft submitted to ground effect</b> Cristian-Emil MOLDOVEANU, Andre GIOVANNINI, Henri-Claude BOISSON, Pamfil ȘOMOIAG	<b>121</b>
❖ <b>Local correlations for flap gap oscillatory blowing active flow control technology</b> Cătălin NAE	<b>127</b>
❖ <b>A Lagrange multiplier approach for Darcy-Stokes flow</b> Alin POHOAȚĂ, Emil LUNGU, Adrian CARABINEANU	<b>134</b>
❖ <b>The determination of the parameters characterizing a cycle of the pulsatory vesicle</b> Dumitru POPESCU, Alin Gabriel POPESCU	<b>140</b>
❖ <b>Internal flow modelling for combustion chamber of turbojet engines</b> Constantin ROTARU	<b>149</b>

❖ <b>A method for aerodynamic interference calculation of some non-planar body-tails arrangements</b>	<b>157</b>
Mihai NEAMȚU, Ștefan NEBANCEA	
❖ <b>Aerodynamic parametric study for a small UAV</b>	<b>165</b>
Mihai Victor PRICOP, Nicolae MARIN	
<b>SECTION 2. Flight Mechanics and Systems Integration</b>	<b>169</b>
❖ <b>Multicopter, multifunctional VTOL flying platform</b>	<b>171</b>
Florin FRUNZULICĂ, Sorin DINEA	
❖ <b>Future directions to be followed in the development of military aircraft maneuverability</b>	<b>176</b>
Alexandru GHEORGHIU, Mircea BOȘCOIANU	
❖ <b>Integrated modelling concept of helicopter dynamics considering body rotor couplings for multidisciplinary design optimization and flying qualities</b>	<b>182</b>
Achim IONIȚĂ, Sorin Ștefan RADNEF, Ionel POPESCU	
❖ <b>Jet engine thrust on ground determination method using differential GPS</b>	<b>196</b>
Neculai PĂUN	
❖ <b>Common aspects and differences in the behaviour of classical configuration versus canard configuration aircraft in the presence of vertical gusts, assuming the hypothesis of an elastic fuselage</b>	<b>201</b>
Octavian PREOTU, Alexandru DUMITRACHE, Mihai Aureliu LUNGU	
<b>SECTION 3. Astronautics and Astrophysics</b>	<b>211</b>
❖ <b>An overview of theory and design of sonic electromagnetic gravitational spacecraft (SEGS)-Part 1-Principles and theory</b>	<b>213</b>
Constantin SANDU, Dan BRAȘOVEANU	
❖ <b>An overview of theory and design of sonic electromagnetic gravitational spacecraft (SEGS)-Part 2-Design considerations</b>	<b>224</b>
Constantin SANDU, Dan BRAȘOVEANU	
❖ <b>Earth – Mars similarity criteria for martian vehicles</b>	<b>232</b>
George SAVU, Octavian TRIFU	
❖ <b>Relative motion of tethered bodies with respect to circular orbits</b>	<b>241</b>
Ion STROE, Petrișor-Valentin PÂRVU	
<b>SECTION 4. Materials and Structures</b>	<b>249</b>
❖ <b>Structural health monitoring with piezoelectric wafer active sensors – predictive modeling and simulation needs</b>	<b>251</b>
Victor GIURGIUȚIU	
❖ <b>Practical aspects of the use of infrared thermography as NDT for aerospace structures</b>	<b>267</b>
Viorel ANGHEL, Nicolae CONSTANTIN, Andreea BORÎTU, Mircea GĂVAN, Ștefan SOROHAN	
❖ <b>Analysis of a composite material landing gear from a light aircraft</b>	<b>272</b>
Dragoș Alexandru APOSTOL, Matei Constantin MIRON, Dan Mihai CONSTANTINESCU, Marin SANDU, Dorin ROȘU, Mădălina STOICA	
❖ <b>Buckling of flat plates under axial loading a comparison between numeric methods and hand calculations</b>	<b>279</b>
Radu BÎSCĂ, Bogdan CALOIAN	



❖ <b>ALOAD - a code to determine the concentrated forces equivalent with a distributed pressure field for a FEM analysis</b>	<b>285</b>
Daniela BARAN, Nicolae APOSTOLESCU	
❖ <b>Loads in the design of flight vehicles</b>	<b>293</b>
Dorin LOZICI-BRÎNZEI, Simion TĂTARU, Daniela BARAN	
❖ <b>Coupling multiphysics phenomena with a single FEA solver: MD Nastran</b>	<b>301</b>
Mircea BOCIOAGĂ	
❖ <b>Numerical simulation for UAV wing structure</b>	<b>308</b>
Adina Otilia BOTEANU, Petru MAZĂRE	
❖ <b>Contributions to the romanian agrarian aeroplane realisation by the engineer Radu Manicatide</b>	<b>316</b>
Mircea Dimitrie CAZACU	
❖ <b>Electrothermic actuators with applications in the morphing wing systems</b>	<b>318</b>
Mircea IGNAT, Gabriela HRISTEA, Ioan PUFLEA	
❖ <b>Applications of the magnetostrictive actuators in the aerospace structures</b>	<b>325</b>
Mircea IGNAT, Alexandru-Laurențiu CĂTĂNESCU, Ioan PUFLEA	
❖ <b>Photovoltaic cells based on A<sub>2</sub>B<sub>6</sub> compounds used in space applications</b>	<b>330</b>
Sorina IFTIMIE, Veta GHENESCU, Cristina BEȘLEAGĂ, Tudor Luca MITRAN, Oana PORUMB, Vlad Andrei ANTOHE, Mihai RADU, Cezar TAZLAOANU, Adrian RADU, Lucian ION, Ștefan ANTOHE	
❖ <b>Aerospace ribs functional modeling in Catia V5</b>	<b>341</b>
Sorin ISTOC	
❖ <b>Smart composites based on NiTi alloys</b>	<b>343</b>
Mariana LUCACI, Violeta TSAKIRIS, Delia PATROI, Lucia LEONAT	
❖ <b>Waveguiding in piezoelectric phononic crystals</b>	<b>350</b>
Cristina PACHIU, Jean Louis IZBICKI, Carmen MOLDOVAN	
❖ <b>Analytical and numerical study concerning the behaviour of single-sided bonded patch repairs</b>	<b>357</b>
Adriana SANDU, Marin SANDU, Loredana TERZEA, Gheorghe OPAȚCHI	
❖ <b>An analytical solution for differential equation of a composite plate</b>	<b>365</b>
Ion FUIOREA, Iuliana SPRINȚU	
❖ <b>Effects of epoxy and phenolic polymers additivated with carbon nanotubes and nanostructured silicates on thermo-mechanical, tribological and rheological properties</b>	<b>372</b>
Ana STAN, Ion DINCĂ, Adriana ȘTEFAN, Lavinia GAVRILĂ FLORESCU, Liviu DUMITRACHE, Horia PAVEN	
❖ <b>Structural changes induced by extreme temperatures in multilayer ceramic structures</b>	<b>381</b>
Adriana ȘTEFAN, Sorin DIMITRIU, Victor MANOLIU, Dionezie BOJIN, Gheorghe IONESCU, Constantin VÂLCU	
❖ <b>Torsion in thin walled hollow sections</b>	<b>391</b>
Marcel STERE	
❖ <b>Impact analysis of an aircraft with a small solid body during flight</b>	<b>397</b>
Florian VLĂDULESCU, Constantin CIOLOFAN	
<b>SECTION 5. Systems, Subsystems and Control</b>	<b>405</b>
❖ <b>Attenuation of sound emissions of turbofan aircraft engines</b>	<b>407</b>
Ștefan BALINT, Agneta M. BALINT, Mirela DARAU	

❖ <b>Unmanned aircrafts and guided missiles, configurations, technical solutions, performances</b>	<b>412</b>
Teodor-Viorel CHELARU, Nicolae MARIN, Adrian CHELARU	
❖ <b>Free flight vs. centralized air traffic management</b>	<b>420</b>
Bogdan DONCIU, Octavian Thor PLETER	
❖ <b>Analysis of the miniaturized inertial sensors stochastic errors with the Allan variance method: a review</b>	<b>428</b>
Teodor Lucian GRIGORIE, Mihai Aureliu LUNGU, Ioana Raluca EDU, Radu OBREJA	
❖ <b>Data encryption solution for secured radio communications with mini UAV- SACT Boreal5</b>	<b>438</b>
Gheorghe GUIMAN, Gigi-Daniel BUDARIU, Gabriel TÂRȘA, Ionuț RĂDOI	
❖ <b>Upgrading the turbojet engine test bench at Aerostar SA</b>	<b>446</b>
Laurian Tiberiu MOCANU, Alexandru Tristian BALMUȘ, Anton PAL, Adrian DUMITRESCU, Ștefan POPA	
❖ <b>Prediction of pilot induced oscillations</b>	<b>456</b>
Valentin PANĂ	
❖ <b>Minimum time control and minimum energy problem for linear systems in Hilbert spaces</b>	<b>463</b>
Mihai POPESCU	
❖ <b>Methodologies for robust control of piezoelectric smart structures. Theoretical and experimental results</b>	<b>471</b>
Ioan URȘU, Lucian IORGA, Adrian TOADER, George TECUCEANU	
❖ <b>Unfalsified control; application to automatic flight control system design</b>	<b>487</b>
Andrei-Sorin NEAMȚU, Adrian-Mihail STOICA	
❖ <b>Reducing fuel consumption in Bucharest terminal area for flights using a standard instrument departure</b>	<b>496</b>
Alin George DIACONU, Octavian Thor PLETER, Virgil STANCIU	
❖ <b>Some aspects regarding the modeling of highly pressurized squeeze film dampers</b>	<b>504</b>
Laurențiu MORARU	
<b>SECTION 6. Experimental investigations in aerospace sciences</b>	<b>509</b>
❖ <b>Synchronized processing of flight test parameters with audio-video information provided by the avionics system of IAR 99 ȘOIM aircraft</b>	<b>511</b>
Eugen DUMITRU	
❖ <b>Numerical simulation of DFB-FL sensors for aeronautical applications</b>	<b>515</b>
Ion LĂNCRĂNȚAN, Sorin MICLOȘ, Dan SAVASTRU	
❖ <b>Antithermal shield for rockets with heat evacuation by infrared radiation reflection</b>	<b>524</b>
Ioan RUSU	
❖ <b>Regarding the evaluation of the solid rocket propellant response function to pressure coupling</b>	<b>529</b>
Doru SAFTA, Titică VASILE, Ioan ION	
❖ <b>Design of a compact six-component force and moment sensor for aerodynamic testing</b>	<b>539</b>
Marin SANDU, Adriana SANDU, Georgeta IONAȘCU	
❖ <b>Wind tunnel testing of the IAR 99 ȘOIM aircraft equipped with means for discovery and control of weather risk phenomena</b>	<b>545</b>
Pătru SPĂȚARU, Florin MUNTEANU, Nicolae MARIN	

❖ <b>Experimental research methodology applied to wind turbine aerodynamic by means of Stereo PIV</b>	<b>553</b>
Corneliu-Ioan STOICA, Radu BOGĂȚEANU	
<b>SECTION 7. Management in aerospace activities</b>	<b>557</b>
❖ <b>Data mining techniques used in aeronautics industry</b>	<b>559</b>
Maria ANDRONIE, Mihai ANDRONIE	
❖ <b>New applications of enterprise resource planning in the aeronautics industry</b>	<b>564</b>
Maria ANDRONIE, Mihai ANDRONIE	
❖ <b>Management based on costs in the aeronautic industry and research in Romania</b>	<b>568</b>
Aurelian Virgil BĂLUȚĂ	
❖ <b>Overview on educational FP7 project - REStARTS - Raising European Students Awareness in Aeronautical Research Through School-Labs</b>	<b>576</b>
Claudia DOBRE	
❖ <b>Advanced aerospace management of integrated education and training towards comprehensive security</b>	<b>579</b>
Miroslav KELEMEN, Pavel NEČAS, Peter TEREM	
❖ <b>Some aspects regarding "Sense and Avoid" requirements for UAV integration in the national air space</b>	<b>583</b>
Adrian MURARU, Gheorghe MATIȘ	
❖ <b>Aircraft "Advanced Jet Trainer/ Light Fighter Jet"</b>	<b>591</b>
Sorin Ștefan RADNEF, Victor EMANOIL	
❖ <b>From collaborative network organization towards future internet enterprise systems in aeronautics industry</b>	<b>594</b>
Aurelian Mihai STĂNESCU, Ioan DUMITRACHE, Mihnea Alexandru MOISESCU, Ioan Ștefan SACALA, Irina Gabriela LOLU	
❖ <b>Integrating the safety dimension in modern air traffic management</b>	<b>604</b>
Virgil STANCIU, Irina Carmen ANDREI, Gabriela Liliana STROE	
<b>List of Authors</b>	<b>613</b>
<b>Authors Index</b>	<b>625</b>



## **SECTION 1. Aerodynamics**



# Evolutionary, Iterative Optimum-Optimorum Theory

Adriana NASTASE

RWTH-AACHEN, Templergraben 55, 52062 Aachen, Germany  
nastase@lafaero.rwth-aachen.de, Aerodynamik des Fluges

**Abstract.** *The performing of the aerodynamical, global optimized (GO) shape of flying configurations (FCs) leads to an enlarged variational problem with free boundaries. The optimum-optimorum theory was developed by the author in order to solve this enlarged variational problem, inside of a class of FCs, with some chosen common properties. This theory was used for the inviscid GO shape of three models with high aerodynamical performances, namely: ADELA (a delta wing alone) and of two integrated wing-fuselage FCs FADET I and FADET II, flying in supersonic flow. The refinement of the optimization strategy, in form of an evolutive, iterative optimum-optimorum theory, is here presented. The inviscid GO shape of FC, represents now only the first step of this iterative method. A computational checking of this shape is made by using new hybrid analytical-numerical solutions for the Navier-Stokes layer. The total drag coefficient (including friction) is computed and a weak interaction aerodynamics/ structure, via new and/or modified constraints is proposed. Up the second step of iteration process, a migration in the drag functional and in the constraints is performed.*

**Key Words:** *enlarged variational method, Navier-Stokes layer, supersonic flow, weak interaction aerodynamics/structure, deterministic optimization, genetic algorithms properties.*

## 1. INTRODUCTION

The classical variational problem, concerning the aerodynamical optimization of the shape of a FC with a given planform, leads to a classical variational problem with fixed boundaries. The author has two times enlarged this variational problem, in order to be able: to determine the GO shape of the FC and to include the friction effect in the computation of the total drag functional and in the optimal design.

The first enlargement consists in the determination of the inviscid GO shape of the FC (namely, the simultaneous optimization of its camber, twist, thickness and also of its similarity parameters of the planform), which leads to an enlarged variational problem with free boundaries. An own optimum-optimorum (OO) theory was developed in order to solve this enlarged variational problem. The inviscid GO shape of FC is chosen in the frame of a class of admissible FCs with good suited common properties.

The OO-theory was used by the author for the aerodynamical GO of the shapes of three aerospace models, namely: of ADELA (a delta wing alone) and of two integrated wing-fuselage FCs FADET I and FADET II, optimized, respectively, for the cruising Mach numbers 2.0, 2.2 and 3.0.

The second enlargement of the variational method, used here, consists in the development of an iterative OO-theory, which takes the inviscid GO of the FC's shape, previously determined, as first step of iteration.

This shape is checked by using the new developed hybrid analytical-numerical solutions for the Navier-Stokes layer (NSL), which use the analytical hyperbolic potential solutions of the flow over the same FC twice, namely firstly as outer flow and secondly the velocity's components are considered between the corresponding components of the potential velocity and polynomial expansions with arbitrary coefficients, as in [1].

The friction drag coefficient is computed and this FC's shape is also controlled for the structure point of view.

Up the second step of iteration, the total drag coefficient is the new functional and the new and/or modified set of constraints, resulting after a weak interaction aerodynamics/structure, are considered. The evolutive, iterative optimum-optimorum theory can be used for the refinement of GO shape of FC.

## 2. THE OPTIMUM-OPTIMORUM THEORY

The first enlargement consists in the inviscid GO shape of the FC (namely, the optimization of its camber, twist and thickness distributions and also of its similarity parameters of the planform), which leads to an enlarged variational problem with free boundaries.

## Prediction of ice shapes and effects of roughness on aerodynamic performance

Maria ALEXANDRESCU, Nicușor ALEXANDRESCU  
 INCAS – National Institute for Aerospace Research "Elie Carafoli"  
 Bdul Iuliu Maniu, no. 220, Bucharest 061136, Romania  
 malex@incas.ro

**Abstract.** In this work are presented the calculations of ice shapes in the presence of roughened formations and are represented the resulting drag increases and lift decrease. The present paper applies the combination of XFOIL code and the interactive boundary layer (IBL) method to predict ice shapes and their effect on airfoil performances. The ice accretion is computed on the airfoil leading edge as a function of time with user specified time intervals. At each given time, the heat transfer calculations can be performed. As the ice accretion builds up its shape may become rugged especially in the case of glaze ice which is characterized by horns and a rough, irregular surface, and leads to higher aerodynamic losses unlike the rime ice. This calculation are effected for clean and iced NACA 0012 airfoil and observe the difference for their performances, lift and drag.

### 1. INTRODUCTION

Considerable care is taken in the design and construction of wings to ensure that the shape provides the required combination of lift and drag over the flight cycle and that the surface is aerodynamically smooth. The formation of ice can change the shape of the wing and this paper examines the magnitude of the effects on lift and drag and describes the status of calculation methods which can provide a basic tool for their prediction.

The ice acts as an equivalent sand grain roughness. Roughness can be incorporated in the solution of boundary-layer or the Navier-Stokes equations provided the characteristics of the roughness are known.

First section of the paper considers the component of a method, based on more fundamental equations, to calculate the performance of airfoils as a function of shape, angle of attack and Reynolds number.

One procedure is described in greater detail and the ways of accommodating changes to the airfoil shape and surface roughness are considered. It involves the numerical solution of conservation equations in differential form and has been used to obtain results which are presented.

### 2. NUMERICAL METHOD FOR ICED AIRFOILS

The calculation method is based on the solution of the two-dimensional incompressible boundary-layer equations, which employ the eddy-viscosity concept to model the Reynolds shear-stress term

$$\frac{\partial u}{\partial x} + \frac{\partial v}{\partial y} = 0 \quad (1)$$

$$u \frac{\partial u}{\partial x} + v \frac{\partial u}{\partial y} = u_e \frac{du_e}{dx} + v \frac{\partial}{\partial y} \left( b \frac{\partial u}{\partial y} \right) \quad (2)$$

where  $b = 1 + \varepsilon_m / \nu$ . On the airfoil, Eqs.(1) and (2) are subject to the boundary conditions:

$$y = 0, \quad u = v = 0 \quad (3a)$$

$$y = \delta, \quad u = u_e(x) = u_e^0(x) + \delta u_e(x) \quad (3b)$$

where  $u_e^0(x)$  denotes the inviscid velocity and  $\delta u_e(x)$  the perturbation velocity due to viscous effects which is given by:

$$\delta u_e(x) = \frac{1}{\pi} \int_{x_a}^{x_b} \frac{d}{d\sigma} (u_e \delta^*) \frac{d\sigma}{x - \sigma} \quad (4)$$



# AN IMPROVED ANALYTICAL SOLUTION FOR 2D INVISCID INCOMPRESSIBLE FLOW THROUGH A CHANNEL WITH WALL FLUID INJECTION AND WALL REGRESSION

Corneliu BERBENTE\*, Sterian D N IL \*, Sorin BERBENTE\*\*

\*Chair of Aerospace Sciences "E.Carafoli", \*\*Chair Engineering of Aeronautical Systems "N.Tipei" UPB, [berbente@yahoo.com](mailto:berbente@yahoo.com)

**Abstract.** One gives an improved extended analytical solution for the inviscid incompressible flow through a 2D channel consisting of four steps: 1) an exact steady simple solution for the potential flow with constant injection speed is first found; 2) the analytical extension of the steady solution to the arbitrary injection speeds is done by using a strategy making possible the separation of variables; 3) an exact analytical solution for the unsteady inviscid flow due to wall regression at constant velocity is also given; 4) the analytical extension of the unsteady solution to the arbitrary injection speeds is done by using the same strategy. Examples of calculations for both steady and unsteady flow are also given. This paper is an extension and an improvement of a previous work [8].

## 1. INTRODUCTION

One considers a 2D channel (Fig.1) with parallel walls, the distance between the walls (plates) is  $2a$  and  $L$  is the length. At channel inlet the velocity is constant  $\bar{u}_z(0) = \bar{u}_c$ , while through the walls a fluid of the same kind is injected at the speed  $u_w(z)$ . The ratio  $L/a$  is large enough to neglect channel ends effects.

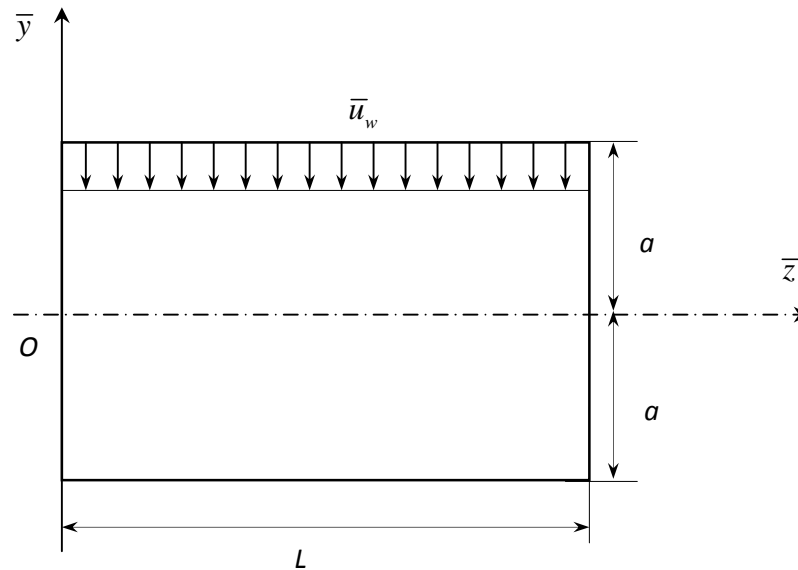

Fig.1

In case the flow is incompressible (density  $\rho = const.$ ) the general equations are (steady flow) [1; 2]

$$\bar{\nabla} \cdot \bar{V} = 0 \text{ (continuity)} \tag{1.1-a}$$

$$\frac{\partial \bar{V}}{\partial t} + \bar{\Omega} \times \bar{V} + \bar{\nabla} \left( \frac{V^2}{2} \right) = -\frac{1}{\rho} \bar{\nabla} p + \bar{\nu} \Delta \bar{V} ; \text{ (momentum)} ; (\bar{\Omega} = \nabla \times \bar{V}) . \tag{1.1-b}$$

$$\rho = const. \text{ (state equation)} \tag{1.1-c}$$

In the above equations,  $\bar{V}(\bar{z}, \bar{y})$  is the velocity vector of components  $\bar{u}_z, \bar{u}_y$ ;  $p, \rho$  are the pressure and the density, respectively, and  $\bar{\nu} = const.$  the kinematic viscosity.

Applying the vectorial operator  $\bar{\nabla} \times$  to the eq. (1.1-b) one obtains:

$$\frac{\partial}{\partial t} (\bar{\nabla} \times \bar{V}) + \bar{\nabla} \times ((\bar{\nabla} \times \bar{V}) \times \bar{V}) = \bar{\nu} \bar{\nabla} \times (\Delta \bar{V}) \tag{1.2}$$

leading to the Helmholtz equations [3] for the rotor  $\bar{\Omega}$  for the plane flows:

# AN ANALYTICAL MODEL FOR INVISCID INCOMPRESSIBLE FLOW AROUND LIFTING SURFACES OF ANY SHAPE

Marius BREBENEL<sup>1</sup>

"POLITEHNICA" University of Bucharest, Romania, Faculty of "Aerospace Engineering"

**Abstract.** Although several 3D models of lifting surfaces are available in the present, a general 3D analytical model, as basis of all existing computing models, wasn't issued so far. Therefore, starting from the general form of Biot-Savart formula applied to a vortex surface of arbitrary shape, the equations of the lifting surfaces were derived by using the Distributions Theory. Also, by applying some additional hypotheses, several equations of type "lifting-line" were found, including Prandtl's equation. The goal of this paper is to highlight the theoretic importance and the general character of the proposed model, by illustrating with some relevant examples.

**Key Words:** lifting surface, lifting line.

## 1. INTRODUCTION

It is known that the first aerodynamic models for wing analysis as 3D lifting surface were issued as early as at the beginning of the aircraft industry. The most relevant of them is the famous "lifting line" model introduced by Prandtl and solved mathematically by Glauert, by expanding the unknown solution in a trigonometric series. The gradually changes in the aircraft design became a challenge for the aerodynamicists, so that new models of analysis were needed. For example, an extension of Prandtl's concept was the Weissinger's model, which allows the analysis of a swept wing. Nowadays, the most used CFD computing model for lifting surfaces is the "vortex lattice", which can be applied on a surface of any shape, providing all the aerodynamic characteristics, including the aerodynamic moment, the position of pressure center and velocity distribution ([1], [2]). The new analytical model, which will be introduced in this paper, is consistent with all the known models, which have been issued under the same assumptions.

## 2. THE GENERAL EQUATION OF THE VORTEX DISTRIBUTION

When a lifting surface is washed by an uniform stream, it behaves like a surface of velocity discontinuities, which can be replaced by a vortex surface. If we denote the vortex field replacing the solid surface by

$$\vec{\gamma}(x, y, z) = \gamma_x \vec{i} + \gamma_y \vec{j} + \gamma_z \vec{k} \tag{1}$$

then the curl of velocity is given by:

$$\vec{\omega}(x, y, z) = \nabla \times \vec{V} = (\vec{n} \cdot \delta_S) \cdot \vec{\gamma}(x, y, z) \tag{2}$$

where  $(\vec{n} \cdot \delta_S)$  is the Dirac "delta" distribution taken on the considered surface [S], defined by the equation

$$\iiint_{R^3} (\vec{n} \cdot \delta_S) \cdot \vec{\gamma}(x, y, z) \cdot dx dy dz = \iint_S \vec{\gamma}(x, y, z) \cdot dS \tag{3}$$

Fig.1 – The vortex field on the solid surface [S] when washed by an uniform stream

<sup>1</sup> PhD, Lecturer

# THE ROTATIONAL VELOCITIES EVALUATION FOR THE ENGINE MOUNTS GYROSCOPIC LOADS

Ștefan BOGOS<sup>1</sup>  
 GECI ENGINEERING SERVICES, Bucharest  
 stefanb@geci.ro

**Abstract.** *The default values for the maximum pitch and yaw speeds from in CS 23.371, seem to be too conservative that would result in overstressing of the structure.*

*A simplified dynamic simulation is proposed to evaluate more confident velocities for a specific aircraft. The yawing condition is related to the "sudden rudder deflection" and a maneuver with "lateral gust". The pitching conditions are a result of a "sudden elevator deflection".*

*The model takes into account nonlinear effects of the aerodynamic coefficients and controls efficiencies.*

## NOMENCLATURE

$b$	= wing reference span,
$S$	= wing reference area,
$C_L$	= lift coefficient,
$C_m$	= pitching moment coefficient,
$C_{mq}$	= pitch damping derivatives,
$C_n$	= yawing moment coefficient,
$C_{nr}$	= yaw damping derivatives,
$I_x, I_y, I_z, I_{prop}$	= moment of inertia in roll, pitch and yaw or propeller,
$M_g$	= gyroscopic moment,
$L, D, T, G$	= lift, drag, thrust, weight,
$M_a$	= aerodynamic pitching moment,
$M_{gust}$	= yawing moment due to the gust load on vertical tail,
$\rho$	= propeller rotation speed,
$V$	= airplane speed,
$V_A$	= design maneuver speed,
$V_B$	= design speed for maximum gust velocity,
$q$	= pitch speed,
$\alpha, \theta, \gamma$	= incidence, pitch angle, slope angle
$r$	= yaw speed,
$\beta$	= airplane sideslip angle,
$\delta_e, \delta_r$	= control surface deflection, elevator or rudder
$t, k$	= time, delay time factor.

## 1. GYROSCOPIC ACTION DUE TO THE AIRCRAFT ROTATIONAL SPEEDS

The rotating components on the aircraft: propeller, engine turbines or compressors are similar with a gyroscope and thus have similar properties.

All practical applications of the gyroscope are based upon two fundamental properties of gyroscopic action: rigidity in space and precession.

Precession is the resultant action, or deflection, of a spinning rotor when a deflecting force or moment is applied to its rim.

As can be seen in the figure 1, when a force (or moment) is applied, the displacement is normal to the direction of the force.

<sup>1</sup> aerodynamics/ loads engineer

# A Vortex Method Approach to Study the Flow about Flapping Wings

Valentin BUTOESCU<sup>1\*</sup>, Andrei CRĂIFĂLEANU<sup>2\*\*</sup>, Ștefan NEBANȚEA<sup>3\*</sup>

\*INCAS - National Institute for Aerospace Research "Elie Carafoli",

\*\*"POLITEHNICA" University of Bucharest

vbutoesc@incas.ro

**Abstract.** *The vortex method has been applied to investigate the flow about flapping wings. The coordinates systems associated to the wings and their kinematics have been presented. The authors have used the vorticity-velocity formulation to enforce the kinematic boundary conditions. They were led to a Fredholm integral equation of the first kind which has been solved numerically.*

## 1. INTRODUCTION

This paper presents the results obtained by the authors during their studies on the aerodynamics and mechanics of the flapping wing air vehicles.

Azuma et al. [1] presented the systems of coordinates related to the flapping wing vehicles and the classical calculation of the aerodynamic forces.

However, some of the coordinate systems proposed in [1] seem to have some inconveniences.

The authors prefer to use the so called "stroke plane coordinate systems" rather than the body geometry frames as used in [1] and also to define the kinematics of both wings to the stroke plane systems.

In a previous paper [2] we presented a similar approach to the problem of the helicopter rotor. So, the aerodynamics of the system of moving lifting surfaces was a subject already developed for the helicopter rotor.

We adapted it for the case of the flapping wing. We did the same with the aerodynamic codes.

The numerical results seem to be good although there is much to be done in order to improve the code and to verify the results.

There are many experimental results concerning the estimation of the global aerodynamic forces on flapping wings, but not as many on load distribution on flapping wings.

## 2. COORDONATE SYSTEMS

In this paper we call *wing* each of the two (sometimes four) aerodynamic surfaces that execute their own flapping motion.

The following coordinate systems are used:

- absolute (or inertial) coordinate system;
- body (flapping **micro air vehicle** -MAV or entomopter) coordinate system;
- wing coordinate systems (for each wing).

### 2.1 Absolute coordonate system

This system ( $X_i, Y, Z_i$ ) is fixed with respect to Earth. The  $Z_i$  axis is vertical and oriented downward.

### 2.2 Body coordinate system

The MAV body usually has a symmetry plane; this plane contains ( $X, Z$ ) axes. The  $Z$  axis is directed downward (i. e. ventrally) and the  $X$  axis is oriented forward.

Denoting by  $\vec{R}_i$  the position vector of a point with respect to the absolute frame, by  $\vec{R}$  the position vector of the same point in the body system and by  $\vec{R}_0$  the position vector of the origin of the boy system, (fig. 1), one can write:

$$\vec{R}_i = \vec{R}_0 + \vec{R} \tag{1}$$

<sup>1</sup> PhD Eng

<sup>2</sup> Associate Professor, PhD Eng.

<sup>3</sup> Math.

## Numerical Investigation of the Free Boundary Flow past an Obstacle

Adrian CARABINEANU\* and Ștefan Gicu CRUCEANU\*\*

\*Department of Mathematics, University of Bucharest, Str. Academiei 14, Bucharest, Romania  
acara@fmi.unibuc.ro

\*\*"Gheorghe Mihoc – Caius Iacob" Institute of Mathematical Statistics and Applied Mathematics of  
Romanian Academy, Calea 13 September No. 13, 050711 Bucharest, Romania  
stefan.cruceanu@ima.ro

**Abstract.** *The paper deals with Helmholtz's model concerning the free boundary flow past an obstacle. We employ Levi - Civita's method in order to reduce the free boundary problem to a system of functional equations. For the obstacles consisting of an arc of circle, one has to solve an integral equation. We utilize the arclength continuation in order to numerically solve the equation and we notice that the solution is unique only for convex obstacles (with respect to the direction of the unperturbed flow at infinity upstream). For concave circular obstacles the integral equations may have two solutions, each solution corresponding to a different obstacle.*

**Key words:** *free boundary flow, Hammerstein equation, discretization, arclength continuation method.*

### 1. INTRODUCTION

In 2d aerodynamics, the occurrence of d'Alembert's paradox is due to neglect of the effects of viscosity. In the second half of the 19th century, assuming that viscosity becomes less important at high Reynolds numbers, focus shifted towards using ideal flow theory for the description of fluid drag. Helmholtz ([7]) proposed a model based on the free boundary flow theory and consisting of a wake behind the body. For the fixed obstacle, assumptions applied to the wake region include zero velocity and a constant pressure.

The wake region is separated - from the potential flow outside the obstacle and wake - by vortex sheets with discontinuous jumps in the tangential velocity across the interface. In order to have a non-zero drag on the obstacle, the wake region must extend to infinity (otherwise d'Alembert's paradox still arises).

Fundamental objections arose against this approach; the main one is that the calculated drag coefficients differ from the drag coefficients found in experiments. These objections were surpassed by combining Helmholtz's theory with boundary layer computations. In the framework of the Euler-Prandtl asymptotic model, Helmholtz's theory is utilized for investigating the free boundary flow past the obstacle and the boundary layer equations are utilized to compute the viscosity effects.

### 2. HELMHOLTZ'S MODEL FOR TWO-DIMENSIONAL INCOMPRESSIBLE POTENTIAL FLOW

We introduce the potential of the velocity  $\varphi$  and the stream function  $\psi$  by means of the relations

$$u = \frac{\partial \varphi}{\partial x} = \frac{\partial \psi}{\partial y}, \quad v = \frac{\partial \varphi}{\partial y} = -\frac{\partial \psi}{\partial x}. \quad (1)$$

Assuming that the flow is irrotational and utilizing the equation of continuity for incompressible fluids we get

$$\text{rot } v = 0, \quad \text{div } v = 0, \quad v = (u, v)$$

whence it follows that the functions  $\varphi$  and  $\psi$  are harmonic:

$$\Delta \varphi = 0, \quad \Delta \psi = 0.$$

At infinity upstream, the flow is assumed to be uniform. The angle between the velocity at infinity upstream and the  $Ox$ -axis is  $\alpha$ , whence it follows

$$\lim_{\infty} (u, v) = (V_0 \cos \alpha, V_0 \sin \alpha). \quad (2)$$

We introduce the complex variable  $z = x + iy$  and the complex potential

$$f(z) = \varphi(x, y) + i\psi(x, y). \quad (3)$$

The complex velocity is

# On the use of lattice Boltzmann methods for reduced order modeling of bluff body aerodynamics

Marius-Gabriel COJOCARU<sup>\*1</sup>, Claudiu-Cristian VĂDEAN<sup>\*\*2</sup>

<sup>\*</sup>INSA Rouen, marius.gabriel.cojocaru@gmail.com

<sup>\*\*</sup>INCAS - National Institute of Aerospace Research “Elie Carafoli”, cvadean@incas.ro

**Abstract.** A combined method of Lattice Boltzmann simulations coupled with Proper Orthogonal Decomposition (POD) of instantaneous velocity fields is developed in order to obtain a Reduced Order Model (ROM).

Lattice Boltzmann methods are becoming a valid alternative to the more conventional CFD simulations, based on the Navier Stokes set of equations, especially when dealing with flows that involve complicated fluid structures and complex boundaries. Moreover, the numerical algorithms based on the Lattice Boltzmann formulation have a more straightforward parallel implementation. Next, why use a Reduced Order Model ?

ROMs are used to obtain fast and accurate results, needed in the areas of flow control and design optimization algorithms. The POD is a powerful tool employed to obtain a Reduced Order Model for the unsteady flow field. In order to achieve that, the eigenmodes of the flow are computed from several snapshots of the instantaneous velocity field spaced uniformly between two shedding cycles and the most energetic ones are used to assemble the Reduced Order Model.

In this paper, two models are constructed and analyzed, one for the case of the flow past a circular cylinder at low Reynolds and another for the flow past a typical bridge section at high Reynolds numbers. In both cases the flow fields obtained with ROMs are compared with the ones obtained from the full simulation and an analysis on the number of modes required to achieve the desired accuracy is presented. In the end, a brief extension towards using Reduced Order Modelling for optimal design is presented.

**Key words:** bluff body aerodynamics, CFD, Lattice Boltzmann methods, Proper Orthogonal Decomposition

## NOMENCLATURE

$\rho$	Density	$a_k$	Time dependent coefficient
$f_a$	Directional densities	$\psi_k$	Mode
$e_a$	Microscopic velocities	$\varepsilon_m$	Average least squares truncation error
$\underline{u}$	Macroscopic velocity	$\lambda_k$	Eigenvalue
$\underline{x}$	Coordinate vector	$\phi_k$	Eigenvector
$w_a$	Weights	$\underline{C}$	Time correlation matrix
$c$	Basic speed of the lattice	$\underline{K}$	Space correlation matrix
$\nu$	Fluid’s cinematic viscosity		<b>Subscripts and Superscripts</b>
$lu$	Lattice unit	k	mode number
$u$	Variable to be reconstructed	a	direction

## 1. INTRODUCTION

In the last two decades, the Lattice Boltzmann Method (LBM) has become an effective numerical tool in the area of Computational Fluid Dynamics (CFD). The technique itself has a wide array of applications. Among many of these directions of research, the modelling of the incompressible Navier – Stokes equation is one the most interesting for the fluid dynamics community.

Indeed, the Lattice Boltzmann equation (LBE) was first proposed to solve the incompressible Navier-Stokes equations. The incompressible Navier-Stokes equations can be derived from the lattice Boltzmann equation through the Chapman-Enskog procedure, if the density fluctuation is assumed to be negligible [1][4].

The essential ingredients in any lattice Boltzmann model, which are required to be completely specified are [2]:

<sup>1</sup> PhD Researcher

<sup>2</sup> PhD Researcher

# AN IMPROVED BEM MODEL FOR THE POWER PREDICTION OF VERTICAL AXIS WIND TURBINES

Radu BOGĂȚEANU\*, Horia DUMITRESCU\*\*, Vladimir CARDOȘ\*\*

\*INCAS – National Institute for Aerospace Research “Elie Carafoli”

\*\* “Gheorghe Mihoc-Caius Iacob” Institute of Mathematical Statistics and Applied Mathematics of Romanian Academy

**Abstract.** *This paper presents a new approach for the prediction of power curves of straight - wing vertical axis wind turbines; it is based on the two dimension aerodynamic properties of airfoil blade elements and some corrections accounting for flow divergence caused by passing across the turbine. The most blade element momentum (BEM) models do not consider the flow divergence, thus they do not fulfill the continuity equation, as the cross sectional area of the stream tube is left unmodified while the wind velocity changes. In this article we present a modified BEM model which combines the conventional approach with a relatively simple numerical analysis based on the balance between the power loss of wind and the power gain of wings. Since the flow divergence is a important factor for accurate loud prediction on the airfoil, it is believed that our model represents a useful working tool for the aerodynamic design of vertical axis wind turbines.*

## 1. INTRODUCTION

In recent years, the wind-generated power gets a lot of visibility as clean and renewable natural energy, as it generates power without generating wastes. Today, the mainstream of large scale wind turbines is in horizontal axis. The horizontal axis turbine is broadly used at any size in course of its long process of development, as it may apply the aircraft propeller theory. On the other hand, the vertical axis turbine is the kind of wind turbine which draws power by turning around vertical axis of rotation to the ground.

The vertical axis turbine can operate irrespective of the direction of the wind, thus has several advantages. First, there is no need of orientation mechanism of wind direction which is necessary for horizontal axis turbine. Also, the installation of heavy materials such as power generator near ground surface is possible. The straight wing vertical axis wind turbine (SWVAWT), the subject of our research today, is advantageous for practical application, as production is easier thanks to the usage of the two-dimensional wing, whose cross sectional profile on the span wise direction is constant.

But there are shortcomings in self-starting performance and the structural mechanism problem on bending moment to the wing. The estimation method of the fluid dynamic performance is still not well defined.

The performance estimation method used for horizontal axis turbine cannot be applied to the vertical axis turbine, due to the structural difference. So far, some performance estimation method are proposed, including methods using single stream tube theory [1], multi-stream tube theory [2], double-multiple stream tube model [3] and numerical analysis such as vortex method [4].

In many cases, those methods such as using momentum conservation law of mainstream direction and power balance toward the force to the wing do not consider the flow divergence and do not fulfill the equation of continuity. Our purpose in this study is based on the concern that it may influence the performance estimation and aim to propose the alternative performance estimation method considering the flow divergence.

To achieve this objective, we take due account of the flow divergence by analyzing the flow around the wind turbines by partly using the numerical analysis. Here we try to develop a highly accurate performance evaluation method: The method is based on two-stage, multi-stream tube actuator disc theory.

Divergence of streamlines can be evaluated by means of numerical analysis, supposing the turbine as porous baffle. Performance estimation is carried out by adjusting the interference factor, so that “power gain by the wing” and “power lost from the wind” are balanced.

## 2. BLADE ELEMENT MOMENTUM THEORY

As shown in Fig. 1(a), the wind passes the wing track twice. Thus we consider the wind turbine as two-stage actuator dividing into upstream and downstream, and we focus on the infinitesimal angular range at each rotational angle when the wind passes along the rotational surface of the

# COMPUTATIONAL STUDIES OF THE EFFECTS OF TURBULENT WALL JET OVER A CURVED SURFACE

Florin FRUNZULICĂ<sup>1,2</sup>, Alexandru DUMITRACHE<sup>2</sup>, Horia DUMITRESCU<sup>2</sup>,  
Vladimir CARDOȘ<sup>2</sup>

<sup>1</sup> “POLITEHNICA” University of Bucharest, Faculty of Aerospace Engineering,  
Polizu 1-7, 011611 Bucharest, ROMANIA, e-mail: ffrunzi@yahoo.com

<sup>2</sup> Institute of Statistics and Applied Mathematics, Calea 13 Septembrie no. 13,  
050711 Bucharest, ROMANIA

**Abstract.** Flow separation, curvature, swirl and rotation are probably most frequently encountered flow phenomena in technical applications.

The particular interest of the present study is Reynolds – averaged Navier-Stokes (RANS) simulations with different turbulence models of the non-equilibrium, turbulent wall jet developing over a curved surface. The flow over cylindrical walls permits examinations of wall jet distortion by combined perturbations in streamwise pressure gradient and surface curvature.

The main goal of this work is to provide a systematic survey of the performance of selected eddy-viscosity models in a range of curved flows and to establish more clearly their potential and limitations.

**Key Words:** wall jet, curved surface, RANS, turbulence models.

## 1. INTRODUCTION

Together with flow separation, curvature, swirl and rotation are probably most frequently encountered flow phenomena in technical applications: aircraft gas turbines, pulverized coal burners, turbomachinery, cyclone separators, centrifugal gas separators, large-scale pipelines systems, etc.

Because of their practical and theoretical importance, numerous experimental investigations, computational modeling and, more recently direct numeric simulations (DNS) and large-eddy simulations (LES) of these flows have been reported in the literature.

Particularly challenging for modeling are flows past curved surfaces that are a complex process provoked, a general, by the interaction between geometry and generated pressure gradients with the flow developing on the surface.

In circumstance in which there is a strong pressure, a closed recirculation region may arise following separation.

Most flows encountered in applications are typically subject to perturbations in external conditions, e.g. pressure gradient and curvature.

Generally, when there is a sudden change in the boundary conditions, such as a change in the pressure gradient and or surface curvature the flow responds by forming an internal layer that grows from the wall.

The particular interest of the present study is Reynolds – averaged Navier-Stokes (RANS) simulations with different turbulence models of the non-equilibrium, turbulent wall jet developing over a curved surface.

The flow over cylindrical walls permits examinations of wall jet distortion by combined perturbations in streamwise pressure gradient and surface curvature.

The particular configuration shown in Figure 1 is considered since cylindrical wall jet properties have been reported by Neuendor and Wygnanski [1] and provide a means for evaluation of simulation results.

By this geometry the flow is subjected to streamwise pressure gradients: the first region, ranging from the end of the potential core to an approximate angular position of  $\theta = 120^\circ$  with a constant surface pressure and the second region is marked by an adverse gradient leading to separation around  $\theta = 230^\circ$ .



## IN-FLIGHT ICE ACCRETION PREDICTION CODE

Vladimir HORÁK\*, Zdeněk CHÁRA\*\*

\*University of Defence in Brno, Kounicova 65, 612 00 Brno, Czech Republic  
vladimir.horak@unob.cz

\*\*Institute of Hydrodynamics, Academy of Sciences of the Czech Republic,  
Pod Patankou 5, 166 12 Praha 6, chara@ih.cas.cz

**Abstract.** *The phenomenon of in-flight icing may affect all types of aircraft. The paper deals with the development of the computational wing airfoil ice accretion prediction code Ice. Presented code versions enable computational rime ice and glaze ice accretion prediction on single and multi-element airfoils in acceptable time of solution. There are presented results of rime ice and glaze ice accretion predictions and compared with current ice accretion prediction codes. Various cases of predicted ice shapes are shown in dependence of air temperature. The latest Ice code version enables to solve system of several airfoils. The example of ice prediction on the wing airfoil with a slotted flap is shown for two angles of deflection.*

**Key Words:** *aircraft icing, ice accretion simulation, icing code.*

### 1. MOTIVATION

The formation of ice on airplane wings occurs when the aircraft flies at a level where temperature is at, or below freezing point and hits supercooled water droplets. The in-flight icing may affect all types of aircraft. Presence of ice on an aircraft surface can lead to a number of performance degradations:

- changes in pressure distribution
- decreased maximum lift and increased drag
- stall occurring at lower angles of attack and increased stall speed
- reduced controllability.

It is important to understand how the different ice shapes affect aircraft aerodynamics. It can be studied by flight tests, wind tunnel measurements, and computational simulations. Computational simulation of ice accretion is an essential tool in design, development and certification of aircraft for flight into icing conditions.

Currently, there exist several approved ice accretion codes:

- LEWICE (LEWIS ICE accretion program) is software developed by the Icing Branch at NASA Glenn Research Center
- CANICE code developed at the Ecole Polytechnique de Montreal
- ONERA (Office National d'Etudes et de Recherches Aérospatiales) code in France
- TRAJICE code which was developed by DERA (Defence Evaluation and Research Agency) in United Kingdom
- CIRA code from Italian Aerospace Research Center.

### 2. ICE ACCRETION PREDICTION CODE

In conjunction with the project of the Czech Ministry of Industry and Trade, was developed the tool for simulating flight into icing conditions. Presented software was subsequently developed and improved. Currently, there are three main code versions:

- R-Ice 1.1 Rime ice accretion prediction [1]
- Ice 3.1 Glaze ice accretion prediction [3]
- Ice 4.1 Multi-element airfoils icing [4]

The *rime ice* is formed if all the impinging water droplets freeze immediately upon impact. It tends to form at combinations of low ambient temperature, low speed (low kinetic heating) and a low value of cloud water concentration.

The *glaze ice* creates at combinations of temperature close to freezing, high speed or high cloud liquid water content. In that case, not all of the impinging water freezes on impact, the thin layer of remainder water is flowing along the surface and freeze at other locations. The process is strongly influenced by the heat transfer.

# ANALYSIS OF LOW-REYNOLDS-NUMBER FLOWS PAST AIRFOILS

Dan MATEESCU<sup>1</sup>

Aerospace Program, Mechanical Engineering Department  
McGill University, Montreal, QC, Canada, dan.mateescu@mcgill.ca

**Abstract.** *This paper presents a method developed by the author and his collaborators for the analysis of the flows at low Reynolds numbers, based on the numerical integration of the Navier-Stokes equations. Recent advances in unmanned and micro-aerial-vehicles (MAV) determined a special interest worldwide for the aerodynamics of airfoils at low Reynolds numbers. The airfoil aerodynamics at these low Reynolds numbers, which is dominated by viscous effects and flow separation phenomena appearing at lower angles of attack, is very challenging and different from those of conventional aircraft. Several authors found that many successful aerodynamic codes developed for the normal range of Reynolds numbers are not well suited for very low Reynolds numbers.*

*The second-order-accurate numerical method presented in this paper, which is characterized by an excellent computational efficiency, has been applied to study the special features of the low-Reynolds-number flows past airfoils, including the pressure distribution, lift and drag coefficients.*

*The complex flow separation phenomena on airfoils at low Reynolds numbers is especially studied by determining the separation onset and reattachment locations and the streamline pattern. A detailed study shows the influence of the Reynolds number, angle of attack, relative thickness and camber on the flow separation and on the aerodynamic characteristics.*

## INTRODUCTION

A special interest has recently been devoted to the aerodynamics of airfoils at low and very low Reynolds numbers. This interest is driven by a variety of applications ranging from domestic windmills to special military aircraft and unmanned aerial vehicles (UAV), which were made possible by the recent advances in the micro-electro-mechanical systems (MEMS). Very small aircrafts called micro-air-vehicles (MAV) can operate in various indoors or outdoors environments including tunnels, desert and jungle (see Davis *et al.* [1] and Mueller [2], who presented a detailed review of MAV concept). Successful design studies for MAV have been presented by various authors, such as Grasmeyer & Keennon [3], Morris & Holden [4], and a recent review paper has been presented by Shyy *et al.* [5]. For a small size micro-air-vehicle (MAV) flying at very low speeds, the Reynolds numbers are as low as 1000 or even lower.

The airfoil aerodynamics at very low Reynolds numbers between 400 and 6000, which is dominated by viscous effects and flow separation phenomena, is very challenging and different from those of conventional aircraft. Several authors [6] found that many successful aerodynamic codes developed for the normal range of Reynolds numbers are not well suited for very low Reynolds numbers. Kunz & Kroo [6] used in their computational study of low Reynolds number flows the INS2D code developed at NASA Ames based on an upwind finite differencing scheme developed by Rogers & Kwak [7].

Recently, a research interest has also been devoted to the confined flows at low Reynolds numbers, with special applications to the cooling flows in electronic devices. Velasquez *et al.* [8] studied the effect of the forced flow pulsations on the laminar heat transfer enhancement behind a 2D backward-facing step in a channel with fixed walls at Reynolds numbers between 20 and 200, and Gerber *et al.* [9] studied the unsteady response of a curved backward-facing compliant step in a flow model related to the aluminum continuous casting operation at the Reynolds numbers 536 and 1055. In a journal paper published this year, Mateescu *et al.* [11] studied the unsteady confined flows at low Reynolds numbers, with applications to the unsteady confined flows with separation regions past a benchmark configuration with a downstream-facing step, which are generated by harmonic variations in time of the inflow velocities and by oscillating boundaries. A detailed analysis of the influence of various geometric and flow parameters on the flow separation phenomena at the fixed and oscillating walls is also presented in [11].

The aim of this conference paper is to present the special features of the flows past airfoils at very low Reynolds numbers, which are obtained with an efficient numerical method based on a pseudo-time integration procedure using artificial compressibility for solving accurately the Navier-Stokes equations. The flow problem is solved in a rectangular computational domain obtained by a

---

<sup>1</sup> Doctor Honoris Causa, FCASI, AFAIAA, Erskine Fellow Professor

# SIMULATION OF WAKE VORTEX AIRCRAFT SUBMITTED TO GROUND EFFECT

Cristian-Emil MOLDOVEANU<sup>1</sup>, Andre GIOVANNINI<sup>2</sup>, Henri-Claude BOISSON<sup>2</sup>,  
Pamfil ŞOMOIAG<sup>1</sup>

<sup>1</sup>Department of Mechanical Engineering Military Technical Academy, No.81-83, George Cosbuc,  
Sector 5, Bucharest, cod 75275, ROMANIA

<sup>2</sup>Institute of Fluid Mechanics, UMR 5502 CNRS/INPT/UPS  
Avenue Camille Soula, 31400 Toulouse, FRANCE

**Abstract.** *The problem developed in this paper is encountered in airplane aerodynamics and concerns the influence of long life longitudinal wake vortices generated by wing tips or by external obstacles such as reactors or landing gears. More generally it concerns 3D bodies of finite extension in cross flow. At the edge of such obstacles, longitudinal vortices are created by pressure differences inside the boundary layers and rotate in opposite senses. It can constitute a danger to another aircraft that flies in this wake, especially during takeoff and landing. In this case the wake vortex trajectories and strengths are altered by ground interactions. This study presents the results of a Large Eddy Simulation of wake vortex in ground effect providing the vorticity flux behavior.*

**Key Words:** *aircraft, wake vortex, large eddy simulation, ground effect, enstrophy, vorticity*

## 1 INTRODUCTION

The vortex mechanisms intervene in a great number of flows and in various forms. In the aeronautical mediums, we can meet vortices which can be of very different scales. Any object moving in the air leaves behind a more or less organized wake. In case of an aircraft, this wake vortex results in a rolling up of the flow starting from the ends of the wings. The aircraft wake vortex can be described by two main counter-rotating vortices.

It is due to the lift of each wing and the generated vortices will be all more intense as this lift will be large.

Vortex decay near the ground is known to be enhanced by proximity to the ground, but details are not well understood.

For aircraft wake vortices away from the ground, ambient atmospheric turbulence has been recognized to be a key factor for the enhancement of the vortex decay [3].

At low altitudes, however, the interaction of the vortices with the ground may be a more important factor for vortex decay.

The aim of this work is to study the vorticity generation for a counter-rotating vortices pair in the ground effect. A three-dimensional numerical Large Eddy Simulation is used.

## 2 GENERATION OF THE VORTICITY AT THE WALL

The concept of vorticity flux has been introduced by Lighthill in 1963. The algorithm generates particles of vorticity at the wall by evaluating at each time step the flux of vorticity (see Cottet and Koumoutsakos for details [6]).

The concept is analog to the Fourier law for the heat flux. We explain this concept in a 2D situation but this can be extended to 3D.

At a plane solid wall extended along Ox axis with normal Oy, the mechanical equilibrium of a fluid particle in projection tangent to the wall writes as:

$$-\frac{\partial p}{\partial x}\Big|_{\text{wall}} + \mu \frac{\partial^2 u}{\partial y^2}\Big|_{\text{wall}} = 0, \quad (1)$$

along with the vorticity at the wall:

$$\omega_z = -\frac{\partial u}{\partial y}\Big|_{\text{wall}}. \quad (2)$$

Combining these two relations we obtain  $\varphi_\omega$  the vorticity flux:

# LOCAL CORRELATIONS FOR FLAP GAP OSCILLATORY BLOWING ACTIVE FLOW CONTROL TECHNOLOGY

Cătălin NAE

INCAS - National Institute for Aerospace Research “Elie Carafoli”  
 Bdul Iuliu Maniu 220, Bucharest 061126, Romania  
 cnae@incas.ro

**Abstract.** Active technology for oscillatory blowing in the flap gap has been tested at INCAS subsonic wind tunnel in order to evaluate this technology for usage in high lift systems with active flow control. The main goal for this investigation was to validate TRL level 4 for this technology and to extend towards flight testing. CFD analysis was performed in order to identify local correlations with experimental data and to better formulate a design criteria so that a maximum increase in lift is possible under given geometrical constraints. Reference to a proposed metric for noise evaluation is also given. This includes basic 2D flow cases and also 2.5D configurations. In 2.5D test cases this work has been extended so that the proposed system may be selected as a mature technology in the JTI Clean Sky, Smart Fixed Wing Aircraft ITD. Complex post-processing of the experimental and CFD data was mainly oriented towards system efficiency and TRL evaluation for this active technology.

**Key Words:** active flow control, experimental fluid mechanics, oscillatory blowing, aeroacoustics.

## 1. INTRODUCTION

Active flow control (AFC), based on oscillatory blowing in the flap gap, was considered as a promising technology able to deliver a new generation of high lift systems, as already introduced in specific investigations [1, 2]. It was demonstrated in the wind tunnel that separation could be limited by oscillatory blowing and specific systems have been successfully used in complex setups [3,4].

A set of wind tunnel tests in AVERT project [5] demonstrated the potential of this technology, mainly with respect to current state of the art capabilities in fluidic actuators and global system design. Major goal of the investigations is related to the possibility of scaling AFC system using oscillatory blowing, so that this technology could be developed to a higher TRL level and implemented in a new generation of aircrafts.

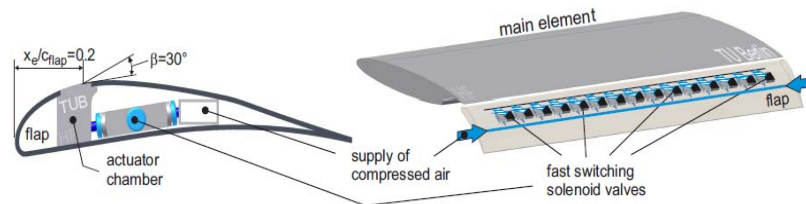

Fig. 1 – AFC using oscillatory blowing

The target configuration for the analysis is a single slotted trailing edge flaps or plain flap respectively, in both 2D and 2.5D configuration. The models are equipped with a specially designed excitation mechanism that is capable of producing a pulsed wall jet with high jet velocities using compressed air and fast switching solenoid valves [3,4] (Fig. 1).

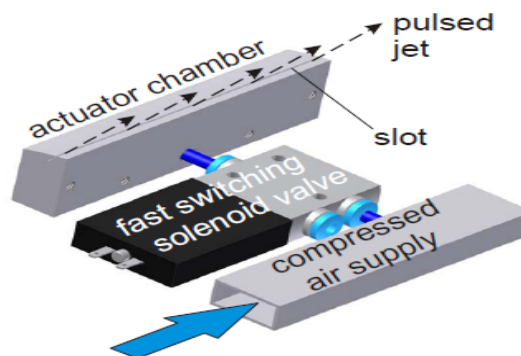

Fig. 2 – AFC system architecture

# A LAGRANGE MULTIPLIER APPROACH FOR DARCY-STOKES FLOW

Alin POHOAȚĂ\*, Emil LUNGU\*, Adrian CARABINEANU\*\*

\*Valahia University of Targoviste alinpohoata@yahoo.com, emil12@rol.ro

\*\*University of Bucharest, Romania, acara@fmi.unibuc.ro

**Abstract.** The aim of this paper is to make a brief introduction to the Lagrange multipliers method for the finite element techniques for Laplace operator. The we extend the method for a family of systems of singular perturbation problems of a saddle point structure using the Mini-element. We compare the results with the results obtained from a stable  $p$ -FEM scheme.

**Keywords:** Finite element, Stokes equation Steklov-Poincaré operator, Schur complement, Lagrange multipliers

## 1. The Lagrange Multipliers Method

The aim of this paper is to present a finite element technique, the Lagrange multipliers method adapted for the for a family of systems of singular perturbation problems.

The basic idea of this method is to consider the Dirichlet data on the boundary as unknowns and later to enforce the equality via some Lagrange multipliers.

At a closer look we observe that this Lagrange multipliers play the role of the discrete normal derivatives.

We remark here the similarities with the Neumann domain decomposition techniques.

Let  $\Omega \subset \mathbb{R}^2$  be a bounded domain with the boundary  $\Gamma = \partial\Omega$  which is assumed to be polygonal. We have to solve the mixed problem:

$$\begin{aligned} -\Delta u &= f && \text{in } \Omega \\ u &= g_D && \text{on } \Gamma_D \\ \frac{\partial u}{\partial n} &= g_N && \text{on } \Gamma_D \end{aligned} \tag{1}$$

where  $\Gamma = \Gamma_D \cup \Gamma_N$  and  $\text{meas}(\Gamma_D) \neq 0$  and  $f \in L_2(\Omega)$ . We define here the operators

$$\begin{aligned} a(u, v) &:= \int_{\Omega} \nabla u \nabla v \, dx : V \times V \rightarrow \mathbb{R} \\ b(v, \mu) &:= \int_{\Omega} v \mu \, ds : V \times M \rightarrow \mathbb{R} \end{aligned} \tag{2}$$

where  $V := H^1(\Omega)$  and  $M := \tilde{H}^{1/2}(\Gamma_D)$ .

The variational formulation of (1) is to find  $(u, \lambda) \in M \times V$  such that

$$\begin{aligned} a(u, v) - b(v, \lambda) &:= \int_{\Gamma_N} g_N v \, ds + (f, v)_0 \quad \text{for all } v \in V \\ b(u, \mu) &= \int_{\Gamma_D} g_D \mu \, ds \quad \text{for all } \mu \in M \end{aligned} \tag{3}$$

where  $(\cdot, \cdot)_0$  is the scalar product in  $L_2(\Omega)$ .

This is a saddle point problem. It is known that the operator  $b$  verifies the *inf sup* condition:

$$\inf_{0 \neq \mu \in M} \sup_{0 \neq v \in V} \frac{b(v, \mu)}{\|\mu\|_M \|v\|_V} \geq 1 \tag{4}$$

If  $a(\cdot, \cdot)$  is elliptic on  $\ker B = \{v \in X \mid b(v, \mu) = 0 \, \forall \mu \in M\}$  then problem (3) has an unique solution (Brezzi Theorem).

We write now  $u = u_i + \tilde{u}_\Gamma$  where  $u_i \in H_0^1(\Omega)$  and  $\tilde{u}_\Gamma = E u_\Gamma$  where  $E: H^{1/2}(\Gamma) \rightarrow H^1(\Omega)$  is the extension operator with respect to the trace theorem.

So we have to find now  $u_i \in H_0^1(\Omega)$ ,  $\lambda \in \tilde{H}^{-1/2}(\Gamma_D)$  and  $u_\Gamma \in H^{1/2}(\Gamma)$  such that:

# THE DETERMINATION OF THE PARAMETERS CHARACTERIZING A CYCLE OF THE PULSATORY VESICLE

Dumitru POPESCU<sup>1</sup> and Alin Gabriel POPESCU<sup>2</sup>

<sup>1</sup>Department of Mathematical Modelling in Life Sciences, Institute of Mathematical Statistics and Applied Mathematics, Romanian Academy of Science, Calea 13 Septembrie, nr. 13, Sector 5, Bucharest-050911, Romania

<sup>2</sup>Department of Computer Sciences, IT CORE SRL, Str. Garoafei, nr.10, sector 5, Bucharest-051235, Romania

**Abstract.** *Under certain conditions, if a lipid vesicle filled with aqueous solution of a substance which is not permeating the vesicle membrane is introduced into a hypotonic aqueous medium, becomes a periodical dynamic device. Due to transmembranar concentration gradient of the impermeable solute, appears an osmotic pressure and water inflows into the vesicle through the lipidic membrane, stretches vesicle, increasing the membrane tension until the membrane until a critical state, when suddenly only a single transmembrane pore at a time appears. The osmotic stress and the transmembrane pore appearance are the two processes which determine the vesicle to experience a periodic process with its swelling and relaxing stages in each cycle. In this paper, we have obtained the parameters characterizing the first cycle of periodical working of pusatory vesicle as a dynamic device. The swelling time which is given by the analytical solution of the differential equation describing the swelling stage of each cycle. Using the numerical integration of a system of three differential equations we have obtained the relaxing time and the final solute concentration inside of the recovered vesicle. The internal substance concentration at the end of a cycle is the most important parameter for the start of the following cycle.*

## 1. INTRODUCTION

The pore appearance in lipid bilayers following some controlled processes may be an adequate and interesting way for transmembrane transport.

The pore appearance in plane lipid bilayer may be influenced by thickness fluctuations [3, 4] or by structural defects [5].

In the lipid vesicle the pore appearance, may be favored by mechanical tension induced by different ways [7]. Recently, a sequence of 30–40 pores was observed in the same giant vesicle, a pore at a time, which can appear in vesicles stretched by optical induced mechanical tension [1, 2, 9]. There are two very interesting biotechnological applications which request the increase of membrane permeability: gene therapy and targeted special substances delivery.

In the last our two papers we have written about how a lipid vesicle has to release the drug molecules, in a well-controlled fashion [7, 8]. It must work as a pulsatory liposome. Its energy is supplied by the concentration gradient across membrane of an impermeant solute.

In this paper, we will make an analysis of the two stages of a cycle from working life of a pulsatory liposome: swelling and relaxation. Before the two part highlighted before, we placed a subchapter which contains a description of the phenomenological base of the running of the pulsatory liposome.

## 2. MATERIAL AND METHODS

### 2.1. Phenomenological base of a pulsatory liposome

Let us consider a liposome filled with aqueous solution containing an impermeable solute. The initial state of the liposome is characterized by smooth and unstretched lipid membrane and by the internal solute concentration.

It is considered as equilibrium reference state. This liposome is inserted into a bath with a hypotonic aqueous medium.

Such, the reference state become the initial state of the liposome dynamics. Due to osmotic pressure, created by the transmembrane gradient of solute concentration, water molecules inflow inside to liposome, across its membrane.

The osmotic flow of solvent determines: 1) the swelling of the liposome; 2) the stretching of liposome membrane; 3) the dilution of the internal solution.

Also, the surface tension increases in the same time with the liposome expansion. The surface tension increases the pressure inside the vesicle, while the osmotic pressure decreases.

# Internal Flow Modelling for Combustion Chamber of Turbojet Engines

Constantin ROTARU

Military Technical Academy, Bdul George Coşbuc 81-83, Bucharest, Romania  
crotaru@mta.ro

**Abstract.** Today’s aircraft propulsion systems have been vastly improved in many ways over the years, but they have remained essentially unchanged in terms of their basic design and operation. The pulse detonation engine (PDE) can potentially achieve higher thermodynamic cycle efficiency and thrust in comparison to traditional constant-pressure combustion gas turbine engines. The most far-reaching applications would be to merge the strengths of current gas turbine in a hybrid propulsion system. The hybrid combinations of pulse detonation engine cycles with turbojet engine cycles offer potential improvements in efficiency. One model of hybrid PDE configuration could be represented by a turbojet engine with multiple PDE detonation tubes around the annular combustion chamber of turbojet. In order to assure the propagation of the detonation down and finally the exhaust of the products into the atmosphere, the last stage of the compressor must assure the periodical flow rate for PDE, so the blades of rotor and stator must have a special shape. In spite of the diffuser and other parts which enlarge the space between the last stage of the compressor and the combustion chamber, the flow at the inlet of the combustion chamber is periodically unsteady. The first part of this study of the hybrid propulsion system consists in modelling and simulation of the combustion in a turbojet engine, so, the paper is focused on the establishment of the link between the control laws of the turbojet engine (whose main parameter is the fuel flow rate in combustion chamber), optimal characteristics of the burned process and the shape of combustion chamber.

**KeyWords:** CFD, combustion chamber, turbojet engine, internal aerodynamics

## 1 INTRODUCTION

The combustion chamber of the turbojet engines (fig.1) is one of the most important components which assures the chemical energy transformation of the fuel in caloric energy and it transmits this energy to the working fluid with a high level efficiency.

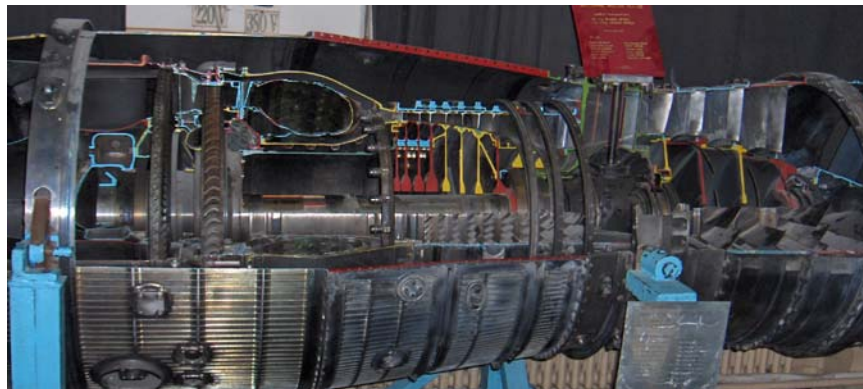

Fig. 1

The mathematical model that describes the operation of the turbojet engine components, from thermogasodynamic point of view, is represented by a system of equation at which the number of the unknown parts is bigger than the number of the equations. In order to solve this system of equations it is necessary to impose additional conditions (control laws).

Choosing a certain control law represents a very important issue, with implications on the height and speed characteristics of the engine.

The control laws of the turbojet engine can be analysed starting from the equation of the set compressor – combustion chamber – turbine [7]

$$\frac{q(\lambda_1)^2 \left( \pi_C^* \frac{\gamma-1}{\gamma} - 1 \right)}{\pi_C^{*2} \left( 1 - \frac{1}{\pi_T^* \frac{\gamma'-1}{\gamma'}} \right) \cdot \eta_C^*} = const. \quad (1)$$

where

## A METHOD FOR AERODYNAMIC INTERFERENCE CALCULATION OF SOME NON-PLANAR BODY-TAILS ARRANGEMENTS

Mihai NEAMȚU, Ștefan NEBANȚEA

INCAS - National Institute for Aerospace Research "Elie Carafoli"

Bdul Iuliu Maniu 220, Bucharest 061126, Romania

neamtu@incas.ro

**Abstract.** *The purpose of this paper is to present a fast, general calculation method of the aerodynamic interference for different non-planar fuselage-tails arrangements, using classical, i.e. non-CFD, methods.*

*To be more specific, such a complex arrangement can be composed of a fuselage with one or two vertical tails and one (symmetrical) horizontal tail, plus, for example one or two ventral fins, etc. However, for the sake of simplicity, in the framework of the present paper, we will treat the most usual combination, fuselage with one vertical and one horizontal tail, without losing the generality of the method.*

*The classical methods are preferred, due to their efficiency, in some cases, such as the early stages of an aircraft design or for calculation of aerodynamic derivatives, especially cross-derivatives.*

*In general, they are useful for situations when some small details of the aircraft configuration, have a non-significant influence on the final results. In such situations simple geometrical models can be used instead of the real configuration of the aircraft.*

*The classical methods are always based on a simplified model, allowing an easy affordable mathematical approach. As generally accepted, the main aerodynamic interference effects between lifting surfaces, come from free vortices induced incidences. In our case, such a simplified model for the vortex interference is the well known Trefftz plane.*

The purpose of this paper is to present the background of a fast general method for the aerodynamic interference calculation in a subsonic flow of velocity  $U_\infty$ , of some **non-planar body-tails arrangements** (the type shown in fig 1), using, so to say, "classical", i.e. non-CFD, methods.

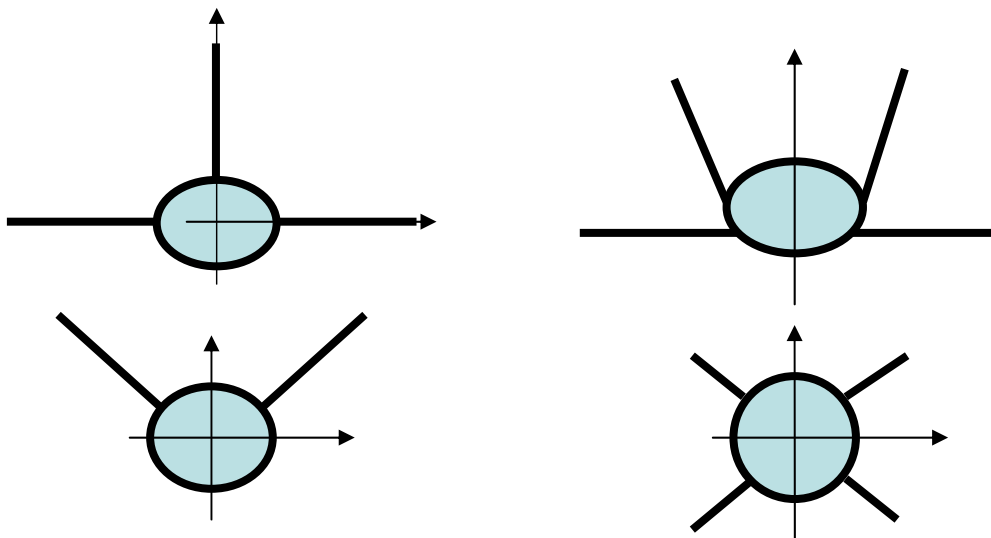

Fig. 1

In some situations, such as the early stages of an aircraft design or when calculating aerodynamic derivatives (especially cross-derivatives) or, more generally, whenever some smaller details of the aircraft configuration have a relatively small contribution on global interference results, the classical methods are preferred for calculation, due to their efficiency in terms of computation time.



## Aerodynamic parametric study for a small UAV

Mihai Victor PRICOP\*, Niculae MARIN\*\*

\*INCAS - National Institute for Aerospace Research "Elie Carafoli", Bdul Iuliu Maniu 220, Bucharest 061126, Romania, vpricop@incas.ro

\*\*Aerospace Consulting, Bdul Iuliu Maniu 220, Bucharest 061126, Romania, marin@incas.ro

**Abstract.** The paper presents results of a parametric study in an effort to develop a small UAV. The design is constrained as payload, size, wing loading, endurance and many other certification parameters, currently too early to be discussed. Preliminary vehicle configurations and their basic aerodynamic characteristics are presented.

### REQUIREMENTS

The intention is to develop an imagery acquisition vehicle, provided with a gimbaled high definition sensor. Some of the requirements for the presented vehicle are:

- Ready to fly mass 3Kg
- Payload 0.5Kg
- Payload consumption: 10W
- Endurance 2h
- Hand launched
- Belly landing recovery
- Transportation box length: 700mm
- Cruising speed 15m/s
- Electric propulsion, noise level

### PRELIMINARY CONFIGURATIONS

The transportation box size is a strong constraint, with respect to the wing span and it's splitting in panels (as well as for the fuselage). It is mandatory to assemble the wing from 0.7m panels. The reasonable choices are three panel wings (two joints) and four panel wings (three joints). Each joint has a weight contribution and decreases the reliability of the system (adding electric connections).

While keeping the wing loading constant (60g/sqdm) and increasing the span, we have an increase in AR from 8.8 to 14, with a reduction of MAC from 0.237m to 0.187m, which corresponds to a Reynolds number reduction from 0.23M to 0.18M.

The airfoil performance is quite sensitive with respect to Re, in this low Re regime, even if it is specifically designed.

The first configuration airfoil is KLH2411 from [1]. The author optimized the NACA 2411 using XFOIL. The predicted performance of the optimized airfoil was 300% of the original, in terms of maximum L/D ratio, which is not credible.

The next three configurations are using a specially designed low Re airfoil, SD6060 (Selig-Donovan), provided with reliable wind-tunnel data as in [2]. However, to better exploit this airfoil, transition tripping must be applied.

Config.	Wing area[sqm]	AR	Wing airfoil	VH	MAC[m]	Re[M]	Remarks
1	0.48	8.8	KLH2411	0.263	0.237	0.23	Poor longitudinal stability
2	0.48	8.8	SD6060	0.525	0.237	0.23	
3	0.518	15	SD6060	0.523	0.187	0.18	
4	0.515	8.57	SD6060	0.517	0.206	0.2	

VH - volume of horizontal tail

MAC – mean aerodynamic chord

AR – wing aspect ratio

## **SECTION 2. Flight Mechanics and Systems Integration**



# Multirotor, Multifunctional VTOL Flying Platform

Florin FRUNZULICĂ, Sorin DINEA

Faculty of Aerospace Engineering, “POLITEHNICA” University of Bucharest,  
Gh. Polizu 1-6, Sect.1, Bucharest 011061, Romania  
ffrunzi@yahoo.com, sorin@aerodin.ro

**Abstract.** *The purpose of the present work is to present a new concept for VTOL flying platform. This aerial vehicle is developed in the PAMMDAV project under national research program PN II. The maximum take off weight for unmanned experimental vehicle is 70 kg and estimated velocity in horizontal flight is 20 m/s.*

*The particularity of PAMMDAV is given by its form, maneuverability and simplicity in use. The central part with axial symmetry are surrounding by 8 independent electrical FAN units simultaneous controlled for obtaining stability and movements around the main axis.*

*The aircraft maneuverability is made by automat control (stability at fix flying point) and manual control (movement and rotation of the vehicle) of thrust for each FAN unit. The rotational speed of half of the FAN's rotors is clockwise and half counterclockwise two by two.*

*The achievement of the multifunctional pilot flying platform, capable of VTOL and having fix flying point for applicability to surveillance activities and taking information (audio, video, chemical, radiations, etc), monitoring and real time interventions, disaster zones, interventions for saving lives and supply, sportive fly with new acrobatically capability.*

**Key Words:** *Unmanned experimental vehicle, VTOL, FAN Units, electrical engines.*

## 1. INTRODUCTION

The project was developed under PN2 research program and it is results as cooperation between “POLITEHNICA” University of Bucharest – Research Center for Aeronautics and Space, Aeronautics and Cosmonautics Romanian Association (ARCA), "Gheorghe Mihoc - Caius Iacob" Institute of Mathematical Statistics and Applied Mathematics (ISMMA), Institute for Theoretical & Experimental Analysis of Aeronautical Structures (STRAERO SA), In Flight Research & Test Center (CCIZ).

The achievement of the multifunctional pilot flying platform, capable of VTOL and having fix floating point for applicability to: surveillance activities and taking information (audio, video, elm, chemical, radiations, etc), monitoring and real time interventions, disaster zones interventions for saving lives.

The initial technical characteristics desired (under 750kg category): take off mass max 590 kg, utile charging max 190 kg, total power units max 285 HP, mass/ power min 2 kg/HP, velocity max 30 m/s, range min 1 h, diameter 5 m.

Unfortunately, the project budget was reduced and the main objective remains to realize a demonstrator of this VTOL concept.

## 2. DESCRIPTION OF VTOL FLYING PLATFORM

### 2.1. Propulsion

Study existing models, both in class UAVs and piloted vehicles, there are two trends in use propeller for sustentation / propulsion namely: free propeller and ducted propeller.

Free rotors raises problems in terms of flow, especially when used a number greater than or equal to 2 rotors.

A series of experiments and numerical calculations have revealed some deficiencies of free rotors:

- Interactions between wakes generated due to the relative position of the rotor from one another.

To limit the effects of interaction between the rotor, unmanned aerial vehicles (UAVs) are preferred spacing to a minimum 1.5-2 rotor diameter, leading to relatively large overall dimensions.

- The procedure for takeoff/landing, recirculating flow occurs with negatively impact performance on the rotors.

- In forward flight, the location of a rotor in the wake of the other rotor increase the non-uniformity of the flow and the initiation of undesirable aeroelastic phenomena such as vibration amplification of plunging.

## Future directions to be followed in the development of military aircraft maneuverability

Alexandru GHEORGHIU<sup>1</sup>, Mircea BOȘCOIANU<sup>2</sup>  
 Air Force Academy "Henri Coanda" Brasov, Romania  
 e-mail: toranoko2003@yahoo.com

**Abstract.** Starting with an introduction to analysis of stability and control of military aircraft, followed by a review of handling and flying qualities, the current research is a synthesis of the dynamics of flight in which the military aircraft handling qualities and advanced technology developments for improving the stability and maneuverability of future military aircraft are discussed. It is presented some examples of aircraft around the world with their capabilities to accomplish multi task missions.

Ever since the first fighter appeared in World War I, agility has been the key as to who survives in an aerial duel. The best way to ensure combat survivability is to have both the best aircraft and the best pilot to fly it. Thus, the emphasis today is on technology that will allow fighters to survive and win in combat. There is great interest today in an area of technology that goes under the generic title of "super-maneuverability."

The term *super-maneuverability* has been expanded to other concepts that can dramatically enlarge the flight envelope of an aircraft in terms of airspeed, turn rate, climb rate, acceleration, and so forth. Super-maneuverability implies capabilities and technology demands beyond those achievable *through more efficient wings*, better performing engines, or more sophisticated flight control systems. Capabilities such as increased usable lift, dynamic lift overshoot, thrust vectoring, and unsteady aerodynamic effects used in synergetic fashion are all means of obtaining greatly enhanced maneuverability.

How well an airplane flies and how easily it can be controlled are subjects studied in aircraft stability and control. By stability we mean the tendency of the airplane to return to its equilibrium position after it has been disturbed. The disturbance may be generated by the pilot's control actions or by atmospheric phenomena. The atmospheric disturbances can be wind gusts, wind gradients, or turbulent air.

An airplane must have sufficient stability that the pilot does not become fatigued by constantly having to control the airplane owing to external disturbances. Although airplanes with little or no inherent aerodynamic stability can be flown, they are unsafe to fly, unless they are provided artificial stability by way of an electromechanical device called a Stability Augmentation System (SAS) Fig. 1.

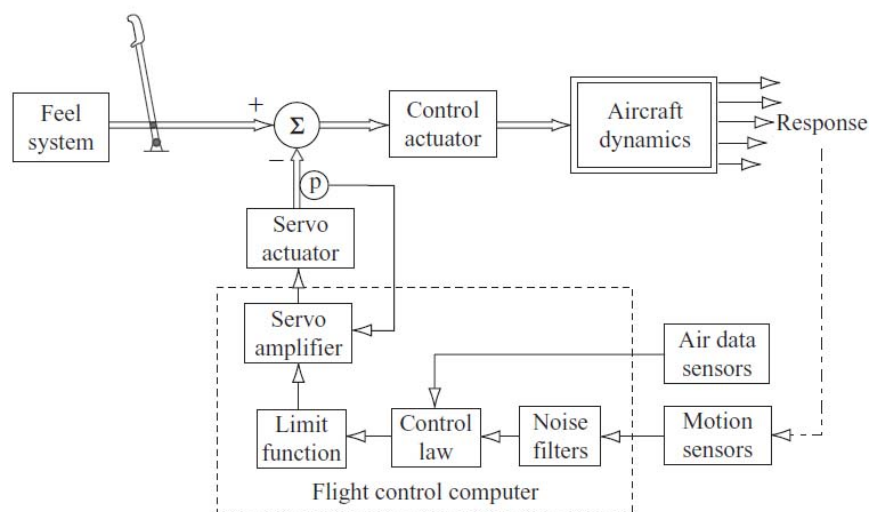

Fig. 1 A typical SAS

<sup>1</sup> Student

<sup>2</sup> Prof. univ. dr. ing. (av)

# Integrated Modelling Concept of Helicopter Dynamics considering Body Rotor Couplings for Multidisciplinary Design Optimization and Flying Qualities

Achim IONIȚĂ\*, Sorin Ștefan RADNEF\*\*, Ionel POPESCU\*

\*Institute for Theoretical and Experimental Analysis of Aeronautical Structures STRAERO, Bucharest, \*\*INCAS - National Institute for Aerospace Research “Elie Carafoli”, Bucharest  
achim.ionita@straero.ro

**Abstract.** *The need for research is particularly acute for rotorcraft because their mathematical complexity, high orders dynamics, multiple scale characteristics and demanding mission requirements.*

*The paper describes the results of both the “in home” research and ongoing effort to develop a helicopter flight dynamics as tool with addition of body rotor couplings contribution. It intends to provide a non real time simulation environment allowing engineers to thoroughly analyze and optimize a rotorcraft in a multidisciplinary framework. Advanced state of the art presently is used to modeling helicopter dynamics looking at the multidisciplinary interaction between the different disciplines during the design process such that: aerodynamics with wake and inflow models, flight dynamics and handling qualities, pilot models including rotorcraft pilot couplings.*

*The flexible solution named HELISTRA will be implemented in MATLAB and for real time and off line simulation FlightLAB and Simulink are utilized. Due to the extensive use of both in house and open source software a sustained and continuous effort is needed for visualization, feedback control design, handling qualities and rotor pilot couplings criteria.*

**Key words:** rotorcraft dynamics, flying qualities, inflow model, wake distortion dynamics, body rotor couplings

## 1. INTRODUCTION

Last two decades, there has been increasing interest in improving the accuracy of flight dynamics mathematical models of rotorcrafts, take in account factors such increasingly stringent handling qualities requirements and reliable design of high gain and high authority flight control systems.

The progress made in joint research teams such AGARD FVP Working Group 18 (Advisory Group for Aerospace Research and Development – Flight Vehicle Integration Panel)[1] and GARTEUR HC AG 16– “Rigid Body and Aeroelastic Rotorcraft-Pilot Coupling (ARPC) – Prediction Tools and Means for Prevention”[2], concerning rotorcraft flight dynamics modeling, design methodologies for helicopter control laws and machine-man couplings are essentially for enhancing of performances, maneuverability and extending of flight envelope. The need for research is particularly acute for rotorcraft because their mathematical complexity, high orders dynamics, multiple scale characteristics and demanding mission requirements [3, 4]. Unlike the flight dynamics of most fixed wing aircraft, the dynamics of rotary wing are characteristically those of high order systems.

The large number of degrees of freedom associated with the coupled rotor-body dynamics leads to a high number of unknowns to be estimated making it rather difficult to successfully asses handling qualities. Due to their unique characteristic, rotorcraft rotors are used to produce lift, control forces and moments as well as propulsive force while for fixed wing aircraft these forces and moments are usually generated through different mechanism. To our knowledge, there has been developed in-house or jointly with the manufacturers several flight dynamics codes dedicated to evaluate the specific helicopter performances. We keep in attention a few of them [5, 6, 7]:

- The FLEXUM code, specialized for the UH-60A helicopter represents the starting point for formulation of the current flight dynamics simulation model.

- The extended UM-GENHEL model based on initially GENHEL helicopter model uses a new trim procedure and it adds the Pitt-Peters dynamic inflow model. It knows as the Pitt-Peters dynamic inflow model and the Peter-He finite state wake model give good results in hover and high forward speed, but accuracy has been lacking at moderate speed in the transitional flight regime. The analysis in frequency domain and the validation study showed that, at least in hover then was a good correlation between calculated results and flight tests data for the on-axis response from 0.5 rad/sec to 15 rad/sec.

Also it has an improving accuracy of calculated results to include the frequency from 0.5 rad/sec to 50 rad/sec with the addition of the flexible blade model.

# JET ENGINE THRUST ON GROUND DETERMINATION METHOD USING DIFFERENTIAL GPS

Neculai PĂUN<sup>1</sup>

Research and Flight Test Center Craiova  
paun@ftc.ro

**Abstract.** This research propose a new method for jet engine thrust on ground determination using the high precision differential GPS(DGPS) model Leica 1230GG with architecture type: fixed receiver – mobile receiver. The method application will be performed on IAR-99 SOIM aircraft equipped with VIPER jet engine.

## 1. INTRODUCTION

Accuracy in engine thrust determination is a very important for aircraft performances. This research propose a new method for jet engine thrust on ground determination using the high precision differential GPS(DGPS) model Leica 1230GG with architecture type: fixed receiver – mobile receiver. The system work under GLONASS and GALILEO standards and can offer a high precision of mobile space point position measurement in hard environmental test conditions: temperature  $-40^{\circ}\text{C} \div 60^{\circ}\text{C}$ , rain, humidity , shocks and vibrations, etc.

In short, the method consist in apliccation of the energy conservation on aircraft ground roll sequence compose by an acceleration, stop engine and stop aircraft. The data of space and velocity of the aircraft will be provide by differential GPS. Using this data like input in a simple mathematical algorithmt, the result will be a maximal engine thrust value with high accuracy.

The method application will be performed on IAR-99 SOIM aircraft equipped with VIPER jet engine.

## 2. INSTRUMENTATION SET-UP ON THE AIRCRAFT

To obtain, during the test, all the data nedeed to compute jet engine thrust, the aircraft dedicated(IAR-99 SOIM) will be equipped with DGPS and data acquisition system like in figures bellow:

Leica receiver

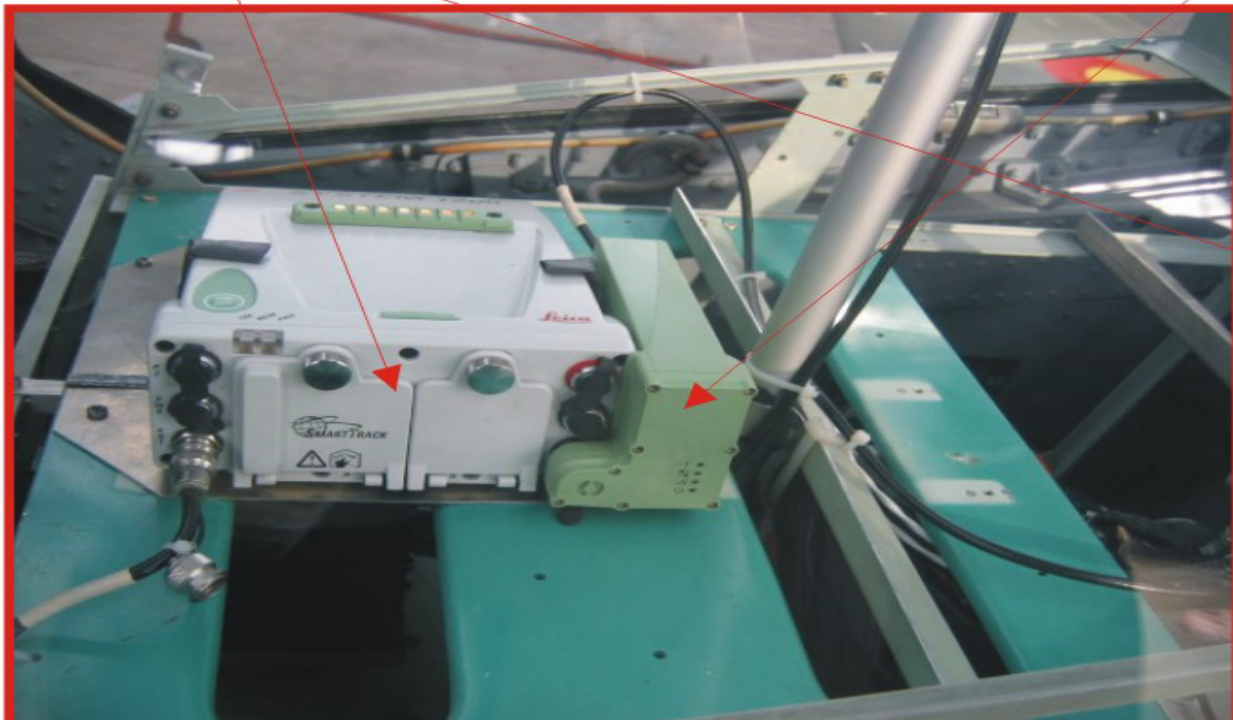

<sup>1</sup> PhD eng.

# COMMON ASPECTS AND DIFFERENCES IN THE BEHAVIOUR OF CLASSICAL CONFIGURATION VERSUS CANARD CONFIGURATION AIRCRAFT IN THE PRESENCE OF VERTICAL GUSTS, ASSUMING THE HYPOTHESIS OF AN ELASTIC FUSELAGE

Octavian PREOTU\*, Alexandru DUMITRACHE\*\*, Mihai Aureliu LUNGU\*

\*University of Craiova, Avionics Department, Craiova, Romania, opreotu@yahoo.com

\*\*"Gheorghe Mihoc-Caius Iacob" Institute of Mathematical Statistics and Applied Mathematics of Romanian Academy

**Abstract.** The paper analyzes, in parallel, common aspects and differences in the behaviour of classical configuration versus canard configuration aircraft in the presence of vertical gusts, assuming the hypothesis of an elastic fuselage. The effects of the main constructional dimensions of the horizontal empennage on lift cancelling and horizontal empennage control are being analyzed.

## 1. THE CANCELLING OF HORIZONTAL EMPENNAGE LIFT IN THE CLASSICAL CONFIGURATION [6]

### 1.1 Classical configuration aircraft. Hypothesis, notations.

Let us consider a classical configuration aircraft, with an elastic fuselage and an arrow angle  $\chi$  at the line of the foci, entering an atmosphere with vertical ascending/descending gusts with an intensity  $w$ , as in fig.1.

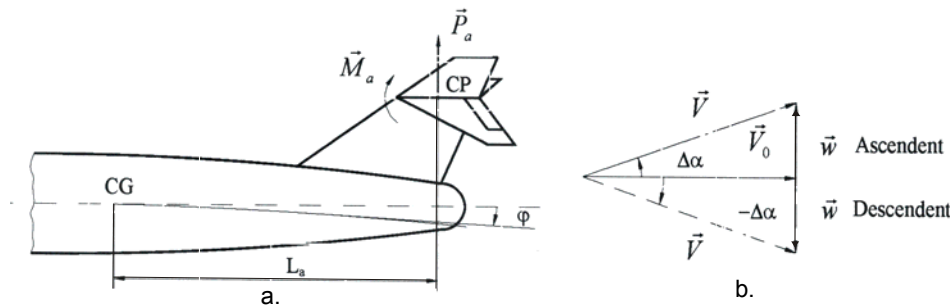

Fig. 1 . Aeronavă în atmosferă perturbată:  
a- sarcini pe fuzelajul deformabil elastic; b- triunghiul vitezelor pentru rafale ascendente și descendente

Using established notations [1,2,3],  $K_1$  și  $K_2$  being the elastic constants for the load  $P_a$  and aerodynamic moment  $M_a$  of the horizontal empennage, the rotation angle of the fuselage along with the horizontal empennage is:

$$\varphi = -\frac{P_a}{K_1} + \frac{M_a}{K_2}. \tag{1}$$

The aerodynamic moment obtained by deflecting the elevator at an angle  $\beta$  is

$$M_a = qS_a c_a \frac{dC_m}{d\beta} \beta \tag{2}$$

With the established notations:  $q = \frac{\rho}{2} V^2$  - dynamic pressure;

$S_a$  -surface of the horizontal empennage;

$c_a = \frac{2}{S_a} \int_0^b c^2(y) dy$  - average aerodynamic string of the horizontal empennage;

$\frac{dC_m}{d\beta}$  - angle of the lift coefficient of the horizontal empennage, which is, as a rule, negative.



## **SECTION 3. Astronautics and Astrophysics**



# An Overview of Theory and Design of Sonic Electromagnetic Gravitational Spacecraft (SEGS)-Part 1-Principles and Theory

Constantin SANDU\*<sup>1</sup>, Dan BRAȘOVEANU\*\*<sup>2</sup>

SC.Turbomecanica SA, Bucharest, Romania, Constantin.Sandu@turbomecanica.ro

\*\* CSC, Washington USA

**Abstract.** *This paper is a developed synthesis of our previous papers presenting a new theory of inertia, gravitation and space propulsion<sup>1</sup>.*

*The aerospace propulsion is currently facing a major crisis. Airplanes and rockets are used for atmospheric and orbital flights, respectively (or aircraft-rocket hybrids like the Space shuttle). The current level of fundamental sciences (especially physics) and the enormous interstellar distances have precluded the development of viable technologies for interstellar flight. Even the nearest stars are out of the reach using star-drive designs envisioned until now.*

*For propulsion, our civilization relies on the Law of Momentum Conservation derived from the Principle of Action and Reaction (Newton’s third law). In other words, until today humanity has known only one method of space flight: to push a mass by throwing matter in the opposite direction with as a high a speed as possible. Basic calculations show this method requires prohibitively large amounts of fuel to propel even minute payloads at low speed. A new type of spacecraft should be considered: the Gravitational Spacecraft, more exactly named the Sonic Electromagnetic Gravitational Spacecraft (SEGS).*

*SEGS do not rely on the law of momentum conservation used until today by all vehicles including rockets. Instead, SEGS rely on the following principles/ laws:*

*A. Use of Artificial Gravitation with High Intensity: Artificial gravitation generated on board pulls the spaceship body.*

*B. The Law of Conversion of Electromagnetic Radiation into Gravitational Radiation which specifies that electromagnetic waves reflecting continuously between two reflective surfaces generate gravitational waves and that primary electromagnetic and gravitational waves have the same frequency.*

*C. The radiant-hull-principle: a spaceship can move in any direction if certain sections of the hull are active and emit gravitational radiation;*

*D. Principle of Sonics (here extended)*

## Content

Chapter 1 – Principles

Chapter 2 – Law of Conversion of Electromagnetic Radiation into Gravitational Radiation

Chapter 3 – Conclusions

## Chapter 1. Principles

### I. Introduction

This chapter presents the four underlying principles of design and operation of Sonic-Electromagnetic-Gravitational-Spacecraft (SEGS).

Subsequent chapter include an in-depth presentation of SEGS physics including the simplest demonstration of the Law of Conversion of Electromagnetic Radiation into Gravitational Radiation.

### II. The Challenge of Space Propulsion

Today, aerospace propulsion is in major crisis. Atmospheric and orbital flights are accomplished using airplanes and rockets, respectively (or an aircraft-rocket combination - the Space shuttle).

The current level of fundamental sciences (especially physics) and the enormous interstellar distances have precluded viable solutions for interstellar flight.

Even the nearest stars are out of the reach of star-drive designs envisioned until now. For propulsion, our civilization relies on the Law of Momentum

Conservation (see fig. 1). In other words, humanity uses only one method of space flight: to push an object by throwing matter in the opposite direction with as a high a speed as possible.

Basic calculation show that this method requires prohibitively large amounts of fuel to propel even minute payloads at low speed and low speed means short range.

---

<sup>1</sup> PhD. Eng.

<sup>2</sup> PhD. Eng.

# An Overview of Theory and Design of Sonic Electromagnetic Gravitational Spacecraft (SEGS)-Part 2-Design Considerations

Constantin SANDU\*<sup>1</sup>, Dan BRASOVEANU\*\*<sup>2</sup>

\* SC.Turbomecanica SA, Bucharest, Romania, Constantin.Sandu@turbomecanica.ro

\*\* CSC, Washington USA

**Abstract.** *This paper continues the part 1 of a previous paper with the same title presenting some design considerations of a new type of spacecraft named SEGS<sup>1</sup>.*

*The present paper includes blueprints of spacecraft hulls designed to convert electromagnetic radiation into gravitational radiation, main reactors, which generate the primary radiation and auxiliary equipment. Spacecraft hull is stratified, having a high number of reflective surfaces. Due to multiple reflections, inside spacecraft hull, a so-called working electromagnetic energy (mainly ultraviolet light) is transformed into gravitational radiation. For this reason, the frequency of working electromagnetic energy decreases from UV or higher to visible light. This visible light is waste energy and is evacuated through the spacecraft hull in order to avoid overheating. For this reason hull shines brilliantly in red, yellow, green, blue or violet. The gravitational radiation emitted by spacecraft hull spans the whole spacecraft body attracting it to the desired direction. Therefore, the spacecraft hull is an important component of the propulsion system. Design, technology and maneuvering of main types of SEGS are presented (planetary, interplanetary and galactic types). Gravitational spacecraft should have simple shapes, such as prism, cylinder and tetrahedron. The acceleration of gravitational spacecraft is limited only by the power of the main reactor because according to Einstein's principle of equivalence between inertia and gravitational fields, the crew feels no inertia.*

## Content

- Chapter 1 – Spacecraft design
- Chapter 2 – Planetary and Interplanetary Ships.
- Chapter 3 – Technology of SEGS
- Chapter 4 – Space Propulsion
- Chapter 5 – Conclusions

## Chapter 1. Spacecraft Design

SEGS is a machine which transforms energy in propulsion. For a better understanding of SEGS working, consider for example the simple case of an internal combustion engine with two strokes (see fig. 1). Fuel has chemical energy, which is converted into thermal energy of working fluid. The blue color represents burnt gases with high energy. In the end, working fluid with low energy, which is shown in red, is evacuated from the engine cylinder (i.e., the working fluid is evacuated from the conversion space). SEGS works in a similar manner, except for the working fluid which is light not burnt gases and the produced power which is gravitational not mechanical.

The components of the simplest spacecraft are presented in fig. 2. This is a planetary spacecraft i.e., it flies close to planets where natural gravitational field is strongly enough. A pulse of electromagnetic energy produced by the electromagnetic wave generator, a, is injected inside the multi-layer hull, 2, where through multiple reflections is transformed in gravitational radiation. The hull surface is spherical or conical therefore the intensity of gravitational radiation decreases rapidly outside ship.

The internal gravitational field is slightly variable between external circumference of spacecraft and restriction cylinder 8. The cabin of these kinds of spacecraft have a central cylinder (outer cylinder 9), this being a characteristic feature of gravitational spacecraft. During flight the crew members must not pass beyond the restriction cylinder 8 because in that area gravitational field is variable and inertia accelerations are strong. Inside the cylinder 7 the gravitational field is weak and inertia accelerations are felt about to the maximum value. The fusion fuel 3 (heavy water in this example) is pumped by aggregates 4 through duct 5 to nuclear reactor, a, which is the electromagnetic wave generator.

Radiated electromagnetic waves are sent to spacecraft reflective layers at a precise incidence angle  $\alpha$  by the central parabolic mirror of gravitational wave generator. Spherical mirror b reflects electromagnetic radiation to parabolic mirror. Inside spacecraft hull electromagnetic waves

---

<sup>1</sup> PhD. Eng.

<sup>2</sup> PhD. Eng.

## Earth – Mars Similarity Criteria for Martian Vehicles

George SAVU\*, Octavian TRIFU\*\*

\*National Research and Development Institute for Gas Turbines –COMOTI,  
Bd. Iuliu Maniu 220C, Sector 6, 061126 Bucharest, Romania  
george.savu@comoti.ro

\*\*Montreal, Canada, octavian.trifu@sympatico.ca

**Abstract.** In order to select the most efficient kind of a martian exploring vehicle, the similarity criteria are deduced from the equilibrium movement in the terrestrial and martian conditions. Different invariants have been obtained for the existing (entry capsules, parachutes and rovers) and potential martian exploring vehicles (lighter-than-air vehicle, airplane, helicopter and Mars Jumper). These similarity criteria, as non dimensional numbers, allow to quickly compare if such a kind of vehicles can operate in the martian environment, the movement performances, the necessary geometrical dimensions and the power consumption. Following this way of study it was concluded what vehicle is most suitable for the near soil Mars exploration. "Mars Rover" has less power consumption on Mars, but due to the rugged terrain the performances are weak. A vacuumed rigid airship is possible to fly with high performances and endurance on Mars, versus the impossibility of such a machine on the Earth. Due to very low density and the low Reynolds numbers in the Mars atmosphere, the power consumption for the martian airplane or helicopter, is substantial higher. The most efficient vehicle for the Mars exploration it seems to be a machine using the in-situ non-chemical propellants: the 95% CO<sub>2</sub> atmosphere and the weak solar radiation. A small compressor, electrically driven by photovoltaics, compresses the gas in a storage tank, in time. If the gas is expanded through a nozzle, sufficient lift and control forces are obtained for a VTOL flight of kilometers over the martian soil, in comparison with tens of meters of the actual Mars rovers.

### 1. INTRODUCTION

The concept of "the in-situ non-chemical propellant production on the martian surface" has been introduced in 1993 when different types of exploring machines using the martian disposable energy (the weak solar radiation and the rarefied atmosphere) have been proposed. Martian missions with autonomous robots of rovers, airship, airplane, helicopter or Mars Jumper type, propelled by the solar energy have been analyzed [1]...[8]. The solar energy is converted in electricity by the photovoltaic cells and is used in real time or, in order to obtain more power, is stocked.

Table 1. Characteristics of the martian atmosphere

Nr.	Normalized parameter	Symbol	Value	Nr.	Normalized parameter	Symbol	Value
1	day duration	$sol$	1.	9	specific heats ratio	$\bar{\kappa}$	0.92028
2	gravity acceleration	$\bar{g}$	0.3953	10	sound speed	$\bar{a}$	0.665
3	pressure	$\bar{p}$	0.007	11	Mach number	$\bar{M}$	1.523
4	density	$\bar{\rho}$	0.0146	12	dynamic viscosity	$\bar{\mu}$	0.72124
5	temperature	$\bar{T}$	0.868	13	kinematic viscosity	$\bar{\nu}$	49.1
6	solar constant	$\bar{k}_s$	0.4316	14	Reynolds number	$\bar{Re}$	0.0204
7	gas constant (state equation of gases)	$\bar{R}_g$	0.658	15	laminar skin friction coefficient	$\bar{C}_{fl}$	7.0
8	molecular mass	$\bar{M}_m$	1.5605	16	turbulent skin friction coefficient	$\bar{C}_{ft}$	2.18

Martian atmosphere composition: 95% CO<sub>2</sub>, 2.7% N<sub>2</sub>, 1.6 %Ar. The exponential decrement of the martian atmosphere ( $\rho = \rho_0 e^{-k_z z}$ );  $k_z = 0.000227756/m$ . An important part of the total mission cost is represented by the numerous tests, performed in special terrestrial installations simulating the martian conditions. It is more convenient to test a martian vehicle in the earthly surroundings and from the obtained results, based to the similarity criteria, to obtain the performances in the real martian atmosphere, than to build sophisticated devices simulating the martian gravity, soil, temperature, solar radiation, pressure, density. In the Table 1 are the some characteristics of the martian environment, normalized to the terrestrial values.

# Relative Motion of Tethered Bodies with Respect to Circular Orbits

Ion STROE, Petrișor-Valentin PÂRVU

\*\*"Politehnica" University of Bucharest, Spl. Independenței 313, Bucharest 060042, Romania,  
ion.stroe@gmail.com, parvu@aero.pub.ro

**Abstract.** This paper deals with motion of tethered bodies. General problem of system kinematics is presented in the first part and the motion of rigid bodies with constraints in the last part. The kinematics of the system is solved for constraints expressed in terms of coordinates and constraints expressed in terms of velocities. The relative motion of systems in central gravitational field with respect to a moving reference frame whose origin is on a circular orbit is presented.

**Key Words:** relative motion of systems in central gravitational field, tethered bodies, motion of rigid bodies with constraints.

## 1. INTRODUCTION

The motion of a multibody system in a gravitational field with respect to a moving reference frame is important to be known. When the motion of a system of bodies which compose a large orbital station is described with respect to reference frames having origin in the center of the attractive body (Earth) the problem of integration of motion equations presents some difficulties, because some coordinates (like vector radii) have very great values, and others (like distances between bodies) have very small values. Some difficulties can be avoided if relative motion of the system is studied with respect to a reference frame with known motion. Relative motion study isn't imposed by integration considerations but by practical aspects.

This paper studies multibody system motion using Lagrange equations for holonomic and nonholonomic systems. Translation conditions and rotation conditions are analyzed. In the case of rigid body motion equation of mass center are completed with motion equation of rotation with respect to mass center. The two kinds of equations (of mass center and of rotation with respect to mass center) can be parted only in particular cases. The kinematics of body systems is solved using coupling mechanism analysis under the aspect of degrees-of-freedom. The motion in central gravitational field is studied with respect to a movable reference frame with origin on a circular orbit. The problem of multibody system dynamics is solved using Lagrange equations of motion with multipliers and constraints. For the system of two tethered bodies obtained results by integration of motion equations are presented. The models and the elaborated method allow solving a large number of multibody systems dynamics problems.

## 2. KINEMATICS OF SYSTEMS OF RIGID BODIES

### 2.1. General problem

Let two bodies (*i*) and (*j*) be with constrained motions by a coupling mechanism which is made precise by points  $O_i, O_j$  Fig. 1. The motion of the body (*i*) with respect the inertial reference frame  $O_0x_0y_0z_0$  is determined by position vector of mass center  $\overline{O_0C_i}$  and by matrix  $[A_{i0}]$  which gives the attitude of  $C_ix_iy_iz_i$  trihedral, jointed with (*i*) body, with respect  $O_0x_0y_0z_0$  reference frame. In the same way are defined position vector  $\overline{O_0C_j}$  and matrix  $[A_{j0}]$  for the body (*j*). Each body, (*i*) or (*j*), has 6 degrees-of- freedom, when it is a free body. The number of degrees-of-freedom is reduced by the number of constrains which are imposed by coupling mechanism. If the general motion of bodies (*i*) and (*j*) with respect the inertial reference frame  $O_0x_0y_0z_0$  are known, then the relative motion of the body (*i*) with respect (*j*) can be determined by the vector

$$\overline{O_jO_i} = (\overline{O_0C_i} + \overline{C_iO_i}) - (\overline{O_0C_j} + \overline{C_jO_j}) \quad (1)$$

and by matrix  $[A_{ij}]$  which gives the attitude of (*i*) body with respect (*j*) body,

$$[A_{ij}] = [A_{i0}][A_{j0}]^T \quad (2)$$

The matrix  $[A_{i0}]$  allows expressing unit vectors of  $C_ix_iy_iz_i$  trihedral with respect unit vectors of  $O_0x_0y_0z_0$  trihedral,

## **SECTION 4. Materials and Structures**





# STRUCTURAL HEALTH MONITORING WITH PIEZOELECTRIC WAFER ACTIVE SENSORS – PREDICTIVE MODELING AND SIMULATION NEEDS

Victor GIURGIUȚIU

University of South Carolina, Department of Mechanical Engineering  
 300 Main St. S., Columbia, SC 29208, USA  
 victorg@sc.edu

**Abstract.** This paper starts a review of the state of the art in structural health monitoring with piezoelectric wafer active sensors and follows with highlighting the limitations of the current approaches which are predominantly experimental. Subsequently, the paper examines the needs for developing a predictive modeling methodology that would allow to perform extensive parameter studies to determine the sensing method's sensitivity to damage and insensitivity to confounding factors such as environmental changes, vibrations, and structural manufacturing variability. The thesis is made that such a predictive methodology should be multi-scale and multi-domain, thus encompassing the modeling of structure, sensors, electronics, and power management. The development of efficient hybrid global-local finite element techniques is advocated and the use of a model-assisted probability of detection approach is absolutely necessary. A few examples of preliminary work on such a structural sensing predictive methodology are given. The paper ends with conclusions and suggestions for further work

**Key Words:** structural health monitoring, SHM, nondestructive evaluation, NDE, piezoelectric wafer active sensors, PWAS, model-assisted probability of detection, MAPOD, hybrid global-local, HGL, finite element method, FEM

## 1. INTRODUCTION

Structural health monitoring (SHM) uses a set of permanently attached sensors to obtain on demand information about the structural performance and state of health [1]. The benefits of monitoring the structural state include design feedback, performance enhancement, on-demand condition-based maintenance, and predictive fleet-level prognosis. On-board structural sensing systems have been envisioned for determining the health of a structure by monitoring a set of sensors over time, assessing the remaining useful life from the recorded data and design information, and advising of the need for structural maintenance actions.

Piezoelectric wafer active sensors (PWAS) have emerged as one of the major SHM technologies; the same sensor installation can be used with a variety of damage detection methods: propagating ultrasonic guided waves, standing waves (E/M impedance) and phased arrays. Structural health monitoring (SHM) is a multidisciplinary process involving several disciplines that must be closely coordinated (**Error! Reference source not found.**).

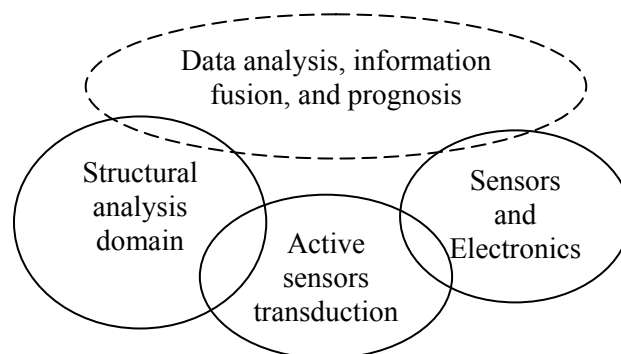

Figure 1 Venn diagram of the multi-domain interaction during structural sensing

Guided-waves techniques for nondestructive evaluation (NDE) and structural health monitoring (SHM) applications are increasingly popular due to their ability to cover large areas with a relatively small number of sensors [2]. Miniaturized guided-wave transducers, such as piezoelectric wafers attached directly to structural elements, have gained large popularity due to their low cost, simplicity, and versatility [3]. These transducers can actively interrogate the structure using a variety of guided-wave methods such as pitch-catch, pulse-echo, phased arrays, and electromechanical (E/M) impedance technique. They can also be used passively for impact detection or acoustic emission (AE). These transducers can be developed into ultra-lightweight

# Practical aspects of the use of Infrared Thermography as NDT for Aerospace Structures

Viorel ANGHEL, Nicolae CONSTANTIN, Andreea BORÎTU,  
Mircea GĂVAN, Ștefan SOROHAN

"POLITEHNICA" University of Bucharest, Department of Strength of Materials, Laboratory for integrity evaluation of composite structures, anghelviorel@resist.pub.ro

**Abstract.** Among different Non-Destructive Evaluation (NDE) methods, Infrared Thermography (IRT) is an emerging method in increasing use for monitoring of aerospace structures. The control of different structures, in manufacturing process or in service is an important aspect for structure life and safety, maintenance cost reduction etc. The importance of NDE methods increases as the market of aging aircrafts has continuously increased. LEISC (Laboratory for Integrity Evaluation of Composite Structures) from University POLITEHNICA Bucharest is currently developing NDE methods based on the ultrasonic guided Lamb waves propagation and on infrared thermography (IRT), methods adapted also for composite and sandwich structures. Some practical conclusions concerning the use of the Infrared Thermography (passive and active) for monitoring the integrity of different type of materials used in aerospace structures are presented with illustrative examples.

**Keywords:** Aerospace Structures, NDT, IRT

## 1. INTRODUCTION

Expanding applications of composite and other new materials and technologies into aerospace structures lead to the need of new appropriate and advanced NDE techniques and SHM systems. The current design philosophy namely *damage tolerant structures* which must withstand certain damage types allowing the stop of their propagation and preserving the structural safety. Damage means changes produced into a system that adversely affect its performance. A NDE technique achieves a comparison between two different states of the system, one of which is assumed the initial or undamaged state. The definition of damage concerns changes of the material and/or geometric properties. A damage which begins at the material level is referred to as a *defect* or *flaw*. Damages can occur in manufacturing or in service due to normal loads, aging processes or accidental events.

One of the emerging methods, in increasing use for monitoring materials and aerospace structures is infrared thermography (IRT). It seems attractive because of its non-contact, non-invasive character and which allows fast inspections of relative large areas [1-4]. In aeronautics, IRT are used especially for: localization of delaminations and disbondings of composite structures, control of the water infiltration in sandwich structures, control surfaces, radoms etc. Other applications concern the diagnosis of the bracket systems and tire, diagnosis of the aircraft deicing systems, identification of cracks and corrosion, power systems examination etc.

This presentation focuses especially on the practical aspects related to the use of passive or active (Lockin and Pulse Thermography) for NDE of aerospace materials and structures. One present several experimental analysis cases, performed in our laboratory on samples made in different materials as: metals, composites, hybrid composites and sandwiches. They are illustrative for several kinds of damage most commonly encountered (delaminations, impact damages, non-uniformities). Some practical aspects related to the use of this technique in laboratory or in situ are also discussed.

## 2. IRT

Thermographic methods are based on the emission of infrared radiation by the surface of the object under investigation. Infrared cameras do not see temperatures, they detect thermal radiation giving an image of the temperature distribution associated with the object. There are two main approaches that can be used: passive and active. The passive one is appropriate for use when the investigated sample has different temperature with respect to the ambient.

The active methods are the Pulse/Flash Thermography, Lockin Thermography and Vibrothermography. In the Pulse Thermography (PT) the heating process consists in a constant flux during several seconds to tens of seconds. The Flash thermography (FT), used especially for metallic structures, uses higher thermal loads obtained by flash injection of heat of typically 10 ms. The decay of the surface temperature is then recorded and analysed. In Lockin thermography (LT),

## Analysis of a composite material landing gear from a light aircraft

Dragoş Alexandru APOSTOL\*, Matei Constantin MIRON\*,  
Dan Mihai CONSTANTINESCU\*, Marin SANDU\*, Dorin ROŞU\*\*, Mădălina STOICA\*

\*Department of Strength of Materials, “POLITEHNICA” University of Bucharest,  
dan.constantinescu@upb.ro

\*\*Compozite SRL, Braşov

**Abstract.** *The paper intends to describe the behaviour of a landing gear from a light aircraft. Having this in mind it was decided to change the manufacturing material with one capable to resist to the same loads but with an improved stiffness to weight ratio. The aluminium landing gear was replaced with a unidirectional glass fibre composite and several tests were performed. The tests were done using a testing machine produced by Walter+Bai, a system that uses the digital method correlation (ARAMIS) and a Höttinger MGC strain unit. Using these equipments it is possible to measure accurately strains in a structural component and to perform also a NDT analysis. The composite landing gear proves to be too flexible, and the use of a carbon fibre material is proposed.*

**Keywords.** *landing gear, composite material, digital image correlation, finite elements*

### 1. INTRODUCTION

Composite materials are used in aerospace applications where high stiffness to weight ratio is very important as to reduce the weight of structural components. The use of a light composite as to replace the actual aluminium 2024 T6 unclad of a landing gear from a lightweight airplane needs a complete analysis of the behaviour of such a structural component. This paper presents an investigation on the mechanical properties of a unidirectional glass fibre composite material together, together with experimental and finite element analyses of a landing gear, by considering the loading cases as recommended by the standards.

In this paper a novel experimental technique is used for analyzing the behaviour of the landing gear. A detailed literature survey of the history of photogrammetry and digital image correlation (DIC) systems is done by Sutton in [1]. In general, DIC is based on the principle of comparing speckle pattern structures on the surface of the deformed and the undeformed specimen or structural component or between any two deformation states. For this purpose, a virtual grid of subsets of a selected size and shape, consisting of certain pixel grey value distributions, is superimposed on the pre-existing or artificially sprayed on surface pattern and followed during deformation by an optical camera system. In this manner, information on the in-plane local strain distribution is gained without assuming a priori the constitutive behaviour of the material. The method finds many applications as in fracture mechanics [2] or fatigue [3] analyses, and its improvements of the sensitivity as discussed in [4] lead to special developments for accurate measurements of the MEMS devices [5]. Other details on the use of the method can be found in [6].

The digital image correlation (DIC) method proves to be effective in analyzing the response of the proposed material of the landing gear by validating the numerical finite element model which is used in obtaining the results presented hereby. Comments on the finite element simulation results are also done in showing if the change of the used composite material is efficient.

### 2. MECHANICAL TESTING OF THE COMPOSITE MATERIAL

Tension and three point bending tests were done in order to determine the properties of the unidirectional fibreglass. After performing the tensile tests the obtained results gave a Young's modulus around 27.3 GPa, a maximum tensile strength of 425 MPa, and a specific deformation at failure of 1.6 % (Fig. 1).

Three point bending tests were done using a span of 72 mm, 104 mm and 132 mm. In table 1 are presented the obtained results after performing the three point bending tests.

It is important to mention the fact that there is a dependency between the span and the overall results; that is, by increasing the span value (distance between supports) the main mechanical properties are lowered due to the local decrease in stiffness of the specimen as it becomes more flexible.

# BUCKLING OF FLAT PLATES UNDER AXIAL LOADING A COMPARATION BETWEEN NUMERIC METHODS AND HAND CALCULATIONS

Radu BÎSCĂ\*, Bogdan CALOIAN\*\*

\*INCAS - National Institute for Aerospace Research "Elie Carafoli",  
Bdul Iuliu Maniu 220, Bucharest 061126, Romania, biscal@incas.ro

\*\*Department of Strength of Materials, "Politehnica" University of Bucharest,  
caloian.bogdan@yahoo.com

**Abstract.** A comparison between the 'exact' and the approximate methods for determining the critical buckling loads under axial loading of prismatic metal flat panels is approached below. The exact method, based on the Classical Plate Theory was improved by the leading airplane manufacturer for over 60 years; the other one is the Finite Element Analysis method. This article aims to determine which of two methods is most suitable for an accurate prediction of the buckling stress acting on the skin panels. The present paper takes into consideration the case of an elastic rectangular flat panel from the aircraft wing upper skin.

## 1. INTRODUCTION

A flat plate loaded by in-plane forces can buckle if the forces induce compressive stresses in the plate. In the classical buckling theory, the plate is able to retain its flat shape under increasing loads until buckling, at which point it undergoes large out-of-plane deflections. The values of the applied loads at which buckling begins are called critical buckling loads. The methods in this article are applicable to plates assumed to be perfectly flat and loaded by in-plane forces only. The provided elastic buckling solutions are consistent with the small deflection theory of plate buckling described in Timoshenko and Gere's "Theory of Elastic Stability".

The buckling analysis of the thin flat plates subject to axial compressive forces by means of the classical buckling theory usually delivers a significantly higher value for the critical load, obtained experimentally and/or by the finite element analysis.

## 2. CLASSICAL PLATE THEORY METHOD

If a wing panel, subject to a single in plane compression loading is considered, the critical buckling stress –  $F_{cr}$  can be calculated from the equation:

$$F_{cr} = \eta K_c E_c \left( \frac{t}{b} \right) \quad (1)$$

The critical buckling stress is smaller than the compressive yield stress –  $F_{cy}$ . The other factors in the equation are the inelastic reduction factor –  $\eta$ , the buckling constant for compression  $K_c$  and the compression modulus –  $E_c$ . The length of the loaded edge is  $b$  and  $t$  is the panel thickness.



Fig. 1. Flat plate load application

The inelastic reduction factor is introduced in the equation when the critical buckling stress exceeds the elastic limit of the material. The value is smaller or equal to 1. For many materials used in aviation,  $\eta$  is already inserted in the buckling curves. The value of  $\eta$  could also be calculated according to the loading and boundary conditions.

$$\eta = \frac{E_s}{E_c} \left( \frac{1}{2} + \frac{1}{2} \sqrt{\frac{1}{4} + \frac{3 E_t}{4 E_s}} \right) \quad (2)$$

where  $E_s$  – secant modulus and  $E_c$  – tangent modulus

The value of the buckling constant –  $K_c$  for a flat plate of various shapes and boundary conditions subject to in-plane loading can be determined with respect to the  $t/b$  report from the next chart.

# **ALOAD - a code to determine the concentrated forces equivalent with a distributed pressure field for a FEM analysis**

Daniela BARAN, Nicolae APOSTOLESCU  
INCAS - National Institute for Aerospace Research "Elie Carafoli"  
Bdul Iuliu Maniu 220, Bucharest 061126, Romania  
dbaran@incas.ro

**Abstract.** *The main objective of this paper is to describe a code for calculating an equivalent system of concentrate loads for a FEM analysis.*

*The tables from the Aerodynamic Department contain pressure field for a whole bearing surface, and integrated quantities both for the whole surface and for fixed and mobile part.*

*Usually in a FEM analysis the external loads as concentrated loads equivalent to the distributed pressure field are introduced.*

*These concentrated forces can also be used in static tests.*

*Commercial codes provide solutions for this problem, but what we intend to develop is a code adapted to the user's specific needs.*

## **1. OBJECTIVES**

*The main objective of this code is to determine an equivalent system of concentrate loads for a FEM analysis. In the same time diagrams of shear forces, bending moments and torsion moments are provided for the Stress Department from the input data of the Aerodynamic Department.*

The tables from The Aerodynamic Department contain pressure fields for a whole bearing surface, and integrated quantities both for the whole surface and for fixed and mobile part. Usually in a FEM analysis the external loads as concentrated loads equivalent to the distributed pressure field are introduced.

These concentrated forces can also be used in static tests.

The commercial codes provide solutions for this problem, but it is useful to develop a code adapted to specific needs.

ALOADS is intended to provide diagrams of the shear force, the bending moment and the torsion moment.

Every aspect is intended to be solved in a friendly environment.

## **2. SHORT DESCRIPTION**

The input data are provided by the Aerodynamic Department as input files for ALOAD. Using these values ALOAD interpolates the pressure values in given structural points (usually the intersections of ribs spars or stingers).

Then these values are integrated and distributed in these structural nodes.

The principal result is a system of concentrated forces equivalent with/ to the initial distribution of the pressure field – the same value of the total force and the same application point.

## **3. INPUT DATA**

The values of the pressure field, shear force, bending and the torsion moment are collected from the Aerodynamic Department.

1. The Stress Department provides the following data which define the finite element model:

- the coordinates of the structural nodes;
- the label (numbers) of these nodes;
- the links between these nodes (the finite element coverage).

The user is supposed to define whether to use a uniform mesh (and if so the user should define it), or a mesh utilized in a commercial finite element code.

An example of input data is given in the following lines.

The interface of this stage is

## LOADS IN THE DESIGN OF FLIGHT VEHICLES

Dorin LOZICI-BRÎNZEI\*, Simion TĂTARU\*\*, Daniela BARAN\*

\*INCAS - National Institute for Aerospace Research “Elie Carafoli”

Bdul Iuliu Maniu 220, Bucharest 061126, Romania

lozicid@incas.ro

\*\*Aerospace Consulting Bucharest, Bdul Iuliu Maniu 220, Bucharest 061126, Romania

aerocons@incas.ro

**Abstract.** *The calculation of flight loads is a critical part of air vehicle design. On the other hand, the prediction of accurate loads is a sophisticated and complex process that requires skilled and experienced engineers. They must integrate results from wind tunnel tests, computer simulations, historical data and empirical formulations into a number of loads cases that provide a realistic assessment of the flight vehicle’s environment.*

*Under these conditions, the vehicle must satisfy requirements imposed by regulatory agencies as part of the vehicle certification process.*

*Loads and boundary conditions can be associated to either the finite element model or the underlying geometry.*

*By associating loads and boundary conditions to the geometry the finite element model mesh and elements can be modified without redefining and applying the loads to the model. Loads and boundary conditions are associated to the model geometry by default.*

**Key Words:** *flight loads, boundary conditions, assessment of the flight vehicle’s environment, finite element method.*

### 1. INTRODUCTION

With FEM analysis, static loads are applied to geometric and scalar points in a variety of ways, including:

- Loads directly applied directly to grid points.
- Pressure loads on surfaces.
- Distributed and concentrated loads on elements.
- Gravity loads.
- Centrifugal loads due to steady rotation.
- Tangential loads due to angular acceleration.
- Loads resulting from thermal expansion.
- Loads resulting from enforced deformations of a structural element.
- Loads resulting from enforced displacements at a grid point.

The import capability allows the user to retrieve an aerodynamic model into the current FEM analysis database.

### 2. AERO-STRUCTURE COUPLING

The aerodynamic and structural models are created and exist as completely separate entities. In the FEM database, any number of structural models and aerodynamics models may exist.

To perform an analysis, a pair of these models must be connected to each other. In aeroelasticity, generating the model so that the aerodynamic forces can be mapped to the structural model (with equilibrium preservation) and than the structural deformation be mapped to the aerodynamic model allowing aeroelastic forces to be computed, is essential.

It is the aero-structure coupling that brings these two models together using splining concepts. There are two basic methods for splines: beam splines and surface splines.

In general, beam splines work well for high aspect ratio wings, bodies and for beam structural models.

Surface splines are suitable for low aspect ratio wings and all built-up structures. Note that, in general, it is the nature of the structural model that determines the best spline choice.

# COUPLING MULTIPHYSICS PHENOMENA WITH A SINGLE FEA SOLVER: MD NASTRAN

Mircea BOCIOAGĂ<sup>1</sup>  
 Magic Engineering Brasov Romania  
 mircea.bocioaga@magic-engineering.ro

**Abstract.** In order to simulate the real world phenomena, it is not enough only to take into account a single approach. For example to study an engineering structure we have to consider not only the mechanical loads but the coupling between several effects such as: thermal effects due to conduction and convection, thermal effects due to radiation, fluid flow inside or outside the structure, mechanical loads applied on the structure, acoustic effects inside and outside of the structure, blast pressure of an explosion and many other effects.

Because of the complexity of the today structures the CAE engineer must use powerful tools to obtain competitive results.

The new released MD Nastran comes with solutions to solve multi-physics phenomena such presented above.

This paper will present applications of coupling different physics phenomena in a single solver: MD Nastran.

## THERMAL-STRESS ANALYS

This example shows how to use SimXpert for a chained thermal/stress analysis.

- It will create thermal lbc for normal heat flux, normal convection, and radiation to space.
- It will also create the structural lbc for pinned ends to electrical leads.
- The thermal/stress analysis simulation parameter values will be defined.
- The results can be viewed after the thermal/stress analysis is performed.

### a. Creating materials with thermal and mechanical properties

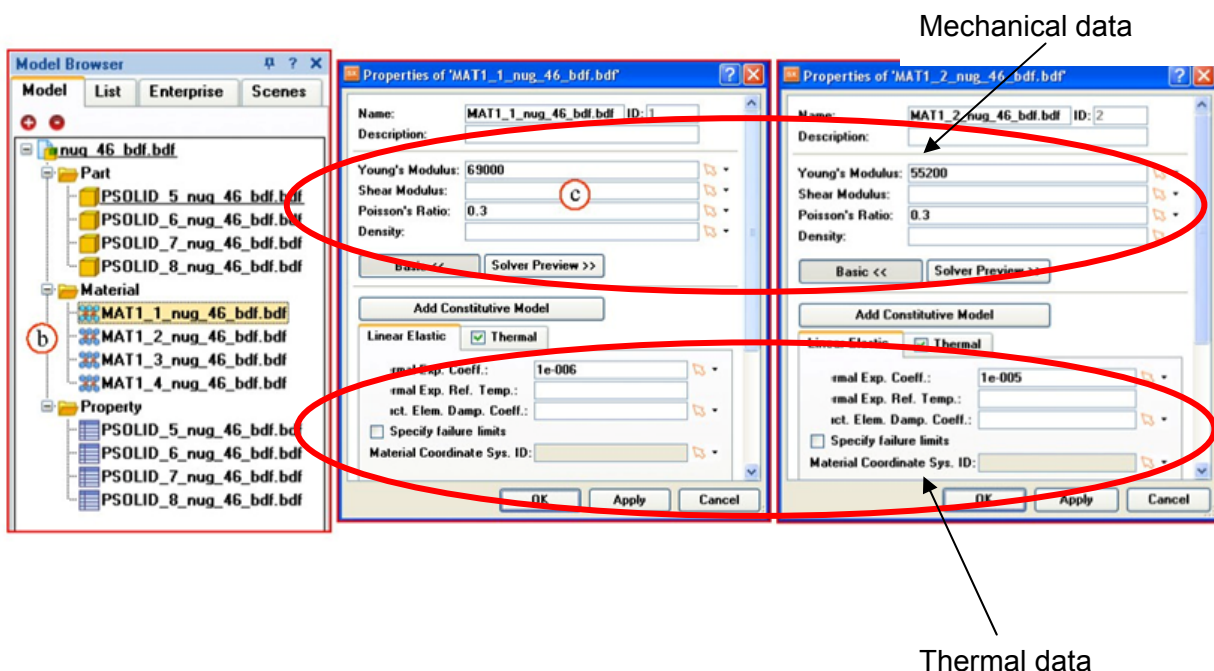

<sup>1</sup> PhD

## NUMERICAL SIMULATION FOR UAV WING STRUCTURE

Adina Otilia BOTEANU<sup>1</sup>, Petru MAZĂRE<sup>2</sup>

Military Equipment and Technologies Research Agency, Information Systems and Communications Test & Evaluation, boteanuotilia@yahoo.com

**Abstract.** *This paper describes a FEM analysis for UAV wing structure having a central spar-torsion panels in comparison with profile I central spar structure.*

*Simulation was based on solution of deformable body mechanics equations system with finite element method.*

**Key words:** UAV, wing, spar, intelligence, reconnaissance

### 1. INTRODUCTION

The resistance structures of the wings can have different configurations depending on the thickness of airfoil, frame curvature profile and position of the maximum frame thickness review of the inboard.

The difficulty of choosing the configuration strength structure, increases with decreasing of the relative thickness and with increasing the curvature of the caring frame.

In case of thin wings airfoil and greater curvature for providing resistance to torsion are used the structures with first and second central spar and ribs in honeycomb configuration (design variant which results in serious complications at rib construction and at assembly).

For this type of wings can not be used effectively the torque spars.

This paper presents a constructive solution which eliminates the need of using variants with ribs in honeycomb configuration and with torsion spars between the ribs by introducing torsion panels between the spars cap.

The spar with torque panels has the advantage of good behavior in bending and torsion compared to the classic spar with the transversal configuration section I or C.

The very good resistance at torsion provides a significant increase of speed of the flight which can appear the flutter phenomena.

The analyzed wing has a rectangular shape in plan and in the front view the shape is straight with heads into the dihedral angle.

The airfoil of the plan is the same with the airfoil heads into the dihedral angle (figure 1).



Fig. 1. UAV wing

The chosen airfoil is K2, a slim airfoil, concave convex, capable of ensuring a high lift force and a low drag force at low flight speed.

<sup>1</sup> Eng. PhD

<sup>2</sup> Eng. PhD



## CONTRIBUTIONS TO THE ROMANIAN AGRARIAN AEROPLANE REALISATION BY THE ENGINEER RADU MANICATIDE

Mircea Dimitrie CAZACU<sup>1</sup>

"POLITEHNICA" University of Bucharest, Hydraulics and Hydraulic Machines Department,  
cazacumircea@yahoo.com

**Abstract.** In this paper the author presents his contributions to the Romanian agrarian aeroplane building, realized by the Engineer Radu Manicatide in the year 1961, concerning the two pump types: centrifugal for the fertilizers and with lateral channel for insecticides, their positioning between the airplane wheels pedestal and the possibility to drive these pumps using the same wind turbine airscrew.

**Key words:** Utilitarian airplanes. Romanian agrarian aeroplane.

Of course I loved for a long time the aviation, but in the year 1949 when I desired to choose in the third year of the Polytechnic Institute of Bucharest, Electro-Mechanic Engineer's Faculty the Aerodynamics speciality direction, where the famous professor Elie Carafoli teaches, I was advised by a German engineer Hans Rameder to choose better the Hydraulic and Pneumatic Machines direction, because after the Second World War, Romania will not have the permission to build airplanes so soon.

This question can explain my enthusiasm, with which I helped my colleague engineer Radu Manicatide to build in the year 1961 at least the utilitarian airplanes, especially the agrarian aeroplane.

Thus, after I was graduated my Hydraulic and Pneumatic Machines speciality in the year 1952 and obtained in the year 1958 the scientific title of PhD Engineer, I was nominated as main scientific researcher at the Hydromechanics Section of the Applying Mechanics Institute, then Fluid Mechanics Institute "Traian Vuia" of the Romanian Academy, director being the acad.prof.dr.eng. Elie Carafoli and in the same time lecturer at the Polytechnic Institute of Bucharest, the Hydraulics and hydraulic Machines Department, where I started to arrange two Laboratories: of Viscous Fluids for the Academy and of Hydraulic and Pneumatics Machines for the Polytechnic Institute, where in the Mechanics Faculty I gave lectures also for the students of both Sections of Hydraulics and Pneumatics Machines and of the Chemical Equipment.

In this quality I succeeded to help the renowned aviation engineer Radu Manicatide to realise the first Romanian agrarian airplane [1], that at a maximum velocity of 140 km/h must to spread such fertilizers, how insecticides through some atomizers mounted on a pipeline disposed at a certain distance under the aeroplane wings (fig. 1), the reservoir for the liquids being situated in cockpit in the pilot backside.

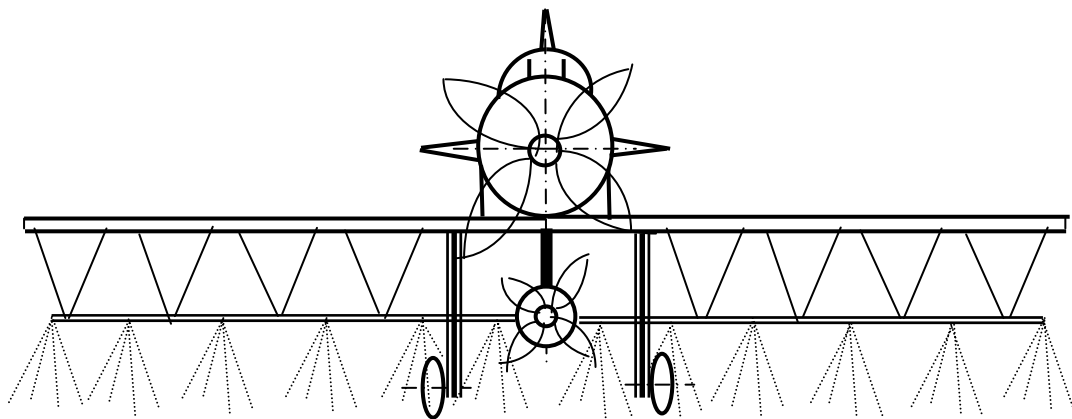

Fig. 1. The schema of the Romanian agrarian airplane realized

The problems disclosed by the engineer Radu Manicatide have been the followings: after the first hardly 70 proof hours from the needed 200 hours, he exposed the Romanian agrarian airplane at the Industrial Exhibition by the side of Spark House, he acquired tens of commands,

<sup>1</sup> Prof. Dr. Eng.

# ELECTROTHERMIC ACTUATORS WITH APPLICATIONS IN THE MORPHING WING SYSTEMS

Mircea IGNAT, Gabriela HRISTEA, Ioan PUFLEA  
National Institute of Electrical Engineering Research-Advanced Research  
INCDIE – ICPE-CA, Dep. MNE, mignat@icpe-ca.ro

**Abstract.** *The authors present two models of the electrothermic actuators based on Joule effect with applications on morphing wing systems:*

- *the bimetallic actuators;*
- *the carbon graphite actuators.*

*The theoretical aspects: the structures of the actuators, the heating effects, the force, the mechanical displacement, the time response and the experimental aspects, the force vs. displacement characteristics, the maximum and the auxiliary temperature effects, the mounting solutions to the morphing wing system are also presented.*

## I. INTRODUCTION

In the past decades, interest in morphing structures has increased due to the benefits they can provide: the structure can change its geometric characteristics and tune its properties to meet the mission's requirements or different load conditions appealing.

A morphing structure requires a flexibility structure. The flexible structure can be altered to different shapes using conventional actuators (hydraulic, electrical) or actuator based on smart materials (carbon, thermo-bimetallic sheet, piezoelectric, magnetostrictive) – [2].

One of the most promising morphing configuration for near term application was found to be a series of trailing edge actuation.

This approach modifies a baseline inflatable wing configuration with piezoelectric (PZT) actuators that flex the trailing edge of the wing.

Unlike ailerons however, the actuators reside under the wing skin, presenting an uninterrupted surface to the air stream – [7].

An equivalent morphing configuration with thermo-bimetallic actuator [8] or carbon material actuator are presented in this paper.

## II. CARBON CHARACTERISTICS

Porous carbons due to their tunable microtexture and surface functionality, high electrical and thermal conductivity and different forms (powders, fibers, felts, foams, etc) offer a wide range of possibilities for electrochemical applications.

Additionally to their amphoteric character they can be doped as well by donor and acceptor species, allowing broadening the properties.

An intense research effort is to develop functional carbon materials with optimized characteristics. The carbon compound used in this study for thermal actuators design was a graphite intercalated compound type GIC-FeCl<sub>3</sub>.

To obtain a porous carbon the synthesized GIC-FeCl<sub>3</sub> (by means of gas-phase chemistry methods) was exposed to a thermal shock. The thermal treatment was performed at 900°C, in a graduated quartz glass beaker placed in an electrical furnace.

Further, the graphite intercalated compound decomposed and instantaneously expanded. After this procedure the expanded volume, V (ml) and net weight W (g) were measured to obtain the specific expansion volume per gram graphite V/W (ml/g). The expansion ratio was as high as 150 times. Thus, a porous carbon material with following characteristics was obtained:

Characteristics: Bulk density: 0.0096 g/cm<sup>3</sup> – 0.01 cm<sup>3</sup>/g;

Surface area (BET area) of expanded graphite: 10 m<sup>2</sup>/g -300 m<sup>2</sup>/g;

Chemical inert and non-toxic.

The resulted carbon flakes were hydraulically pressed into plates.

Bulk density has been determined in accordance with Romanian Standard No. 8432/79 [9] by measuring the mass weight W (g) of an expanded sample, resulting by its free falling in a measured volume V (cm<sup>3</sup>). The ratio between mass weight and measured volume, W/V, gives the specimen bulk density.

# APPLICATIONS OF THE MAGNETOSTRICTIVE ACTUATORS IN THE AEROSPACE STRUCTURES

Mircea IGNAT, Alexandru-Laurențiu CĂTĂNESCU, Ioan PUFLEA,  
National Institute of Electrical Engineering Researche-Advanced Researche  
INCDIE – ICPE-CA, Dep. MNE, mignat@icpe-ca.ro

**Abstract.** *The paper presents the potential utilities of the magnetostrictive linear actuators in the aerospace applications:*

- *The shape modifications;*
- *The morphing wing systems;*
- *The compliant mechanisms;*
- *The fuel electromechanical pumps;*
- *The control drives in the interior of the aerospace cell or in the wind tunnel.*

*The authors present the electromechanical structure and the working principle of the magnetostrictive actuators, the force and displacement characteristics, the energetic balance, the supply parameters, the thermic behaviour and the design elements.*

## I. INTRODUCTION

One of the most promising morphing configuration for near term application was found to be a series of trailing edge actuation. This approach modifies a baseline inflatable wing configuration with piezoelectric (PZT) actuators that flex the trailing edge of the wing. Unlike ailerons however, the actuator reside under the wing skin, presenting an uninterrupted surface to the air steam – [1].

The paper presents a magnetostrictive actuator with applications in the trailing edge actuation. Another potential technology is piezoelectric actuators.

The ratio between magnetic ( $w_m$ ) and electric volume density ( $w_e$ ) justifies the choise of the magnetostrictive technology. At typical values  $B = 1T$  and  $E = 30kV/cm$  the ratio is

$$\frac{w_m}{w_e} = \frac{B^2 / \mu_0}{\epsilon_0 E^2} = 10^4 .$$

An other typical application “magnetostrictive pump” is also presented in the paper.

## II. THEORETICAL ASPECTS

Magnetostrictive materials deform when exposed to magnetic field and change their magnetization state when stressed. The 1D magnetostrictive equation is:

$$M = \chi_m H + e \varepsilon \tag{1}$$

where:  $M[A/m]$  - magnetisation,  $\chi_m$  - magnetic susceptibility,  $H[A/m]$  - magnetic field,  $e[A/m]$  - magnetostrictive stress constant,  $\varepsilon$  - mechanical strain.

The stress constant  $e$  can be expressed by the strain constant  $d$  and Young’s modulus  $Y$ :  $e = dY$ .

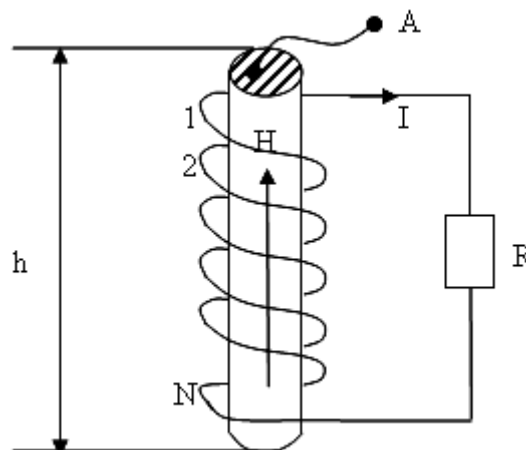

Fig. 1. Simplified model of the magnetostrictive device.

## Photovoltaic cells based on $A_2B_6$ compounds used in space applications

Sorina IFTIMIE<sup>1</sup>, Veta GHENESCU<sup>2</sup>, Cristina BE LEAG<sup>1</sup>, Tudor Luca MITRAN<sup>1</sup>, Oana PORUMB<sup>1</sup>, Vlad Andrei ANTOHE<sup>1</sup>, Mihai RADU<sup>1</sup>, Cezar TAZLAOANU<sup>1</sup>, Adrian RADU<sup>1</sup>, Lucian ION<sup>1</sup>, tefan ANTOHE<sup>1\*</sup>

<sup>1</sup>Department of Solid State Physics, University of Bucharest, 077125, M gurele-Ilfov, 405 Atomi tilor, Romania, santohe@solid.fizica.unibuc.ro

<sup>2</sup>Institute for Space Sciences, 077125, M gurele-Ilfov, 409 Atomi tilor, Romania

**Abstract.** Due to the small quantities of material required for their construction and their suitability for large scale manufacturing techniques, the second generation of solar cells (based on semiconducting thin film) has an enormous potential as a commercially viable source of electricity in the near future. Particularly the development of lightweight solar cells based on polycrystalline thin films from  $A_2B_6$  compounds are interesting for many terrestrial and space applications because of their low cost, high specific power and stable performance.

One of the important requirements for space application is the stability of solar cells against ionizing radiations. Taking into account that the weight of protons in the cosmic rays is about 87%, it is very important to investigate the effect of proton irradiation on the physical properties of used thin films. That is why, we report in this paper the experimental results of high-energy proton irradiations with 3 MeV at  $3 \times 10^{13}$  protons/cm<sup>2</sup> fluency on CdS/CdTe heterojunction solar cells. CdS/CdTe heterostructures have been prepared by conventional vacuum evaporation technique.

The effects of irradiation were studied by investigating the changes in the electrical and optical properties of the cells. It was found that proton irradiation in the above mentioned conditions results mainly in the introduction of defects at the CdS/CdTe interface.

A discussion about the possible origin of these defects is given.

**Key Words:** solar cells, cadmium telluride, thin films, proton irradiation

### 1. INTRODUCTION

Thin film CdS/CdTe photovoltaic cells are among the best candidates for producing low cost and high efficient heterojunction photovoltaic devices [1-5].

They were produced in both superstrate and substrate configurations, using several types of techniques [6].

It is well known that a postdeposition annealing process in the presence of CdCl<sub>2</sub> is necessary to obtain high efficiencies.

Although the exact mechanisms behind this process are not yet fully understood, the CdCl<sub>2</sub> treatment is believed to achieve an enhanced p-type doping of the CdTe layer [7] and a lowering of the series resistance [8].

It is also associated with recrystallization [9,11], grain growth [12], grain boundary passivation [13] and interdiffusion at the CdS/CdTe interface [9,10]. In addition, the good stability of CdTe based solar cells against proton irradiation was demonstrated [14], which recommends them for use in space technology.

Results of studies on the effects of electron and proton irradiation on physical properties of individual layers (i.e. CdS, CdTe and CdSe thin films) were reported elsewhere [15-23]. In the case of proton irradiation, it was found that 3 MeV accelerated proton irradiation, at relatively high fluencies (up to  $10^{14}$  cm<sup>-2</sup>) results mainly in the introduction of point-like defects, acting as traps for free carriers.

But, relatively few works were devoted to study the effect of ionizing irradiation on the performance of photovoltaic cells based on these materials [24].

In this paper we report the results we have obtained on the effects of proton irradiation (3 MeV energy and  $3 \times 10^{13}$  protons/cm<sup>2</sup> fluency) on the main parameters of CdS/CdTe thin film photovoltaic cells.

The aim of this study was to investigate the changes induced in the spectral dependence of the photovoltaic response of the cells by the irradiation with protons in the above-mentioned conditions.

## Aerospace Ribs Functional Modeling in Catia V5

Sorin ISTOC<sup>1</sup>

Magic Engineering Brasov Romania, sorin.istoc@magic-engineering.ro

**Abstract.** CATIA Functional Molded Part - New way of thinking the solid design due to its unique semantic features which enables designers to focus on WHAT they want to model and not HOW to model it.

CATIA is Dassault Systèmes first brand and has become since many years the world's leading solution for Product Design and Innovation and standard de facto in aerospace and automotive. Several thousands of companies in multiple industries worldwide have already chosen the Virtual Design capabilities of CATIA products to ensure their products Real Success. CATIA delivers solutions for the companies from large OEMs through their supply chains to Small and Medium Businesses.

Inside CATIA, you can find a lot of very powerful products which allow users to perform various tasks. Functional Molded Part (FMP) is such a product, based on **Functional Modeling** - a new generation of 3D modeling technology, delivering unmatched productivity and flexibility, based on a new way of thinking the design due to its unique semantic features which enables designers to focus on **WHAT** they want to model and **not HOW** to model it. It's the unique Functional Modeling technology on the market.

CATIA Functional Molded Part provides tools to create volumes and features that contain inherent behaviors and which interact. The behaviors capture different design functions, such as adding material, subtracting material, or protecting space. Because they contain inherent behaviors and they interact (ribs, reinforcements, cutouts, rests, pockets, grills, bosses, drafts, chamfers, lips, etc.), they are called "functional volumes" and "functional features".

Based on this functional behavior, you get a No history-based design (the features creation order is not very important anymore) which rely in design changes flexibility, reduced time to perform changes and update it, great flexibility in introducing and evaluating design changes.

As you can see in the product name – Functional Molded Part- this CATIA workbench is dedicated for parts that are made in molds. In molded part terminology, you talk about Core and Cavity side of a part. These sides of a part are referred inside FMP like **Internal** and **External** in order to be more flexible in approaching various geometries other than typical molded parts (machined parts for example). In this spirit, CATIA manages the part boundaries and you have features that operate inside your part or outside of your part in an automatic way. Also, specific for molded parts, you have access in each feature you create to specific molded part properties like drafts and fillets. All these features are parameterized and you can use all these parameters in knowledgeware entities (like formulas, rules, checks, design tables, etc.).

FMP can be a very good product to design plastic parts or molded/machined aluminum parts. You can see some examples in Figure 1.

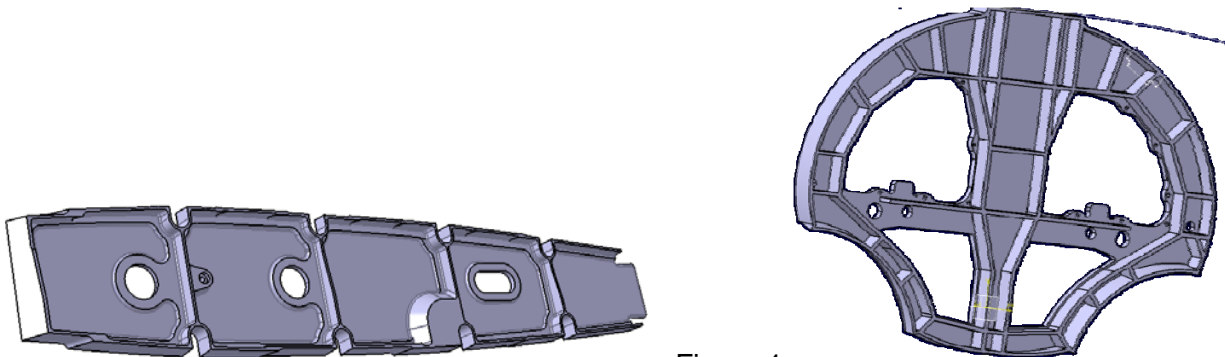

Figure 1

Strictly related to aerospace parts, Functional Modeling reduces the engineering cycle by allowing parallel design. With surfaces from aerodynamic office and using for example a 2D

<sup>1</sup> MSc

## SMART COMPOSITES BASED ON NiTi ALLOYS

Mariana LUCACI, Violeta TSAKIRIS, Delia PATROI, Lucia LEONAT  
National Institute of Electrical Engineering Researche-Advanced Researche  
INCDIE – ICPE-CA, Bucharest, Romania  
lucaci@icpe-ca.ro

**Abstract.** *In the context of mass reduction of the airplanes, the high temperature strength of NiTi alloys can be exploited as potential for the replacement of the Ni-base superalloys used in aerospace industry. The paper presents our research results regarding the obtaining of  $Ti_{(50-x)}Al_x-30 Ni-20Cu$  ( $x = 1, 3, 6$ ) alloys reinforced with coherent low-misfit nanoscale precipitates, by using the spark plasma sintering technique. It was demonstrate that with Al content increasing, both yield strength and ultimate compression strength are increasing and a dispersion of the Heusler phase ( $Ni_2TiAl$ -type with  $L2_1$ ) structure increases the compressive strength value of the material with an order of magnitude up to 660 MPa, in the as-sintered and annealed state.*

### 1. INTRODUCTION

The NiTi alloys can be used as replacement for the Ni base superalloys since these alloys take part from the light weight alloys group.

To make them acceptable for the aerospace applications, it is necessary to improve their mechanical properties (strength, toughness and ductility) and the cyclical lifetime.

One way the reach these properties is to strengthen the metallic matrix by precipitate strengthening mechanisms.

Various types of precipitates might be considered in the Ti-Ni-based system.

On the Ti-rich side of the binary Ti-Ni system, a  $Ti_2Ni$  dispersion can be obtained while on the Ni-rich side, the  $Ni_3Ti/Ni_4Ti_3$  precipitates can be considered as strengthening dispersions.

Kajivara et al. [1] found that subnanometric thin plate metastable bct precipitates are formed in the Ti-rich TiNi sputter deposited films after a subsequent treatment in the 377 - 827 °C interval.

Due to the relatively low heat treatment temperature, the diffusion of Ti atoms is not fast enough to form stable  $Ti_2Ni$  precipitates; instead, Guinier-Preston zone-type precipitates which contain excess of Ti atoms are produced.

With these fine precipitates in the B2 matrix, they could provide a strength of 670 MPa to the material.

Koizumi et al [2] have examined the high-temperature strength of NiTi alloys for aerospace applications.

They have demonstrated that a dispersion of Heusler phase ( $Ni_2TiAl$ -type with  $L2_1$  structure) increases the compressive yield strength of 50.7Ni-40.9Ti-8.4Al (in at%) alloy with an order of magnitude up to 2300 MPa.

This strengthening method is potentially applicable to both thin film and bulk alloy processing and to both types of materials, high strength alloys and shape memory alloys [3, 4].

However, accurate knowledge of the TiNi- $Ni_2TiAl$  phase relation is needed to design high-performance alloys.

According to the known lattice constants [5], there is a lattice misfit between TiNi and  $Ni_2TiAl$  at room temperature, as determined by the following relation:

$$\delta = \left( \frac{a_{Ni_2TiAl} - 2a_{TiNi}}{2a_{TiNi}} \right) = -0.0257 \quad (1)$$

were  $a_{Ni_2TiAl}$  is the lattice parameter of  $Ni_2TiAl$  ( $a = 0.5865$  nm) and  $a_{NiTi}$  is the lattice parameter of NiTi ( $a = 0.3010$  nm).

Lattice misfit arising from different lattice parameters between two coherent phases causes coherency strains with an associated volume strain energy that can affect the precipitate shape, the spatial distribution, and the coarsening behavior [6].

A correlation between the processing technique, structure, properties and performance of the NiTi materials is presented in Figure 1. [4].

## WAVEGUIDING IN PIEZOELECTRIC PHONONIC CRYSTALS

Cristina PACHIU<sup>(1)</sup>, Jean Louis IZBICKI<sup>(2)</sup>, Carmen MOLDOVAN<sup>(1)</sup>

<sup>(1)</sup>National Institute for R&D in Microtechnologies, Erou Iancu Nicolae 126A, Bucharest 077190, Romania, cristinap@imt.ro

<sup>(2)</sup>Laboratoire d'Acoustique Ultrasonore et d'Electronique LAUE UMR 6068 CNRS, Université du Havre, Place R. Schuman, 76610 Le Havre, France

**Abstract.** *We investigate the possibility of designing phononic crystal using materials commonly employed in microfabrication. We focus our attention on a phononic crystal made of a square array of cylindrical holes drilled in an active piezoelectric matrix. This study is aimed to developing a theory of waveguiding formalism for two-dimensional phononic crystal consisting of materials with general anisotropy. Explicit formulations of the plane harmonic surface wave dispersion relations in such a general two-dimensional structure are derived based on the plane wave expansion method (PWE). The present work provides evidences that phononic crystal properties can be integrated with existing silicon based microdevice.*

**Keywords:** *Phononic crystal, Guided waves, Plane-wave-expansion method*

### INTRODUCTION

Phononic crystals are periodic structures created through the repeated placement of one, two- or three-dimensional unit cells. The unit cell is comprised of a host medium in which an inclusion medium is embedded. The host medium and inclusion medium differ in their material properties, such as density and elastic wave velocities. Energy is transmitted through the phononic band gap crystal via an elastic wave<sup>(1)</sup>.

The phononic band structure of a phononic band gap crystal is analogous to the electronic band structure of semiconductors, and the electromagnetic band structure of photonic band gap crystals. The electronic band structure of a semiconductor is a consequence of the wave nature of the electrons present in a periodic lattice of atomic nucleus. The electromagnetic band structure of a photonic band gap crystal results from the presence of electromagnetic waves in a periodic lattice of inclusions, whose dielectric constant contrasts that of the host medium. The phononic band structure results from the presence of elastic waves in the phononic band gap crystal<sup>(1)</sup>.

These properties give potential applications of phononic crystals in communication manufacturing respectively microwave acoustic filters or multiplexers, transducers and sensors<sup>(2)</sup>.

The first progress has been made in the theoretical analysis<sup>(3)</sup> in 1998 and experimental demonstration of phononic crystals<sup>(4)</sup> but the phononic crystal based devices such as waveguides<sup>(7,8)</sup> were developed 10 years later.

Three different schemes were adopted in the calculation of waveguiding and band gaps in phononic crystals, i.e., the plane wave expansion (PWE) method, the multiple scattering method and the finite difference time domain method. Wilm<sup>(9)</sup> applied the PWE method to piezoelectric composite plate structures and analyses the dispersion relations of plate modes and related characteristics. Two years later, Wu<sup>(10)</sup> utilized the PWE method to study the phononic band gaps of surface waves in two-dimensional phononic structures consisting of general anisotropic materials. Kushwaha *et al.*<sup>(11,12)</sup> utilized the PWE method to calculate the first full band structure of the transverse polarization mode of nickel alloy cylinders in aluminum alloy host. Tanaka and Tamura<sup>(3)</sup> also reported the first calculations for surface waves on a square and hexagonal superlattice consisting of isotropic materials Al/polymer.

Garcia-Pablos *et al.*<sup>(13)</sup> used the finite difference time domain method to interpret the experimental data of two-dimensional systems consisting of cylinders of fluids (Hg, air, and oil) inserted periodically in a finite slab of Al host.

In this work, we extend Tanaka and Tamura's formalism<sup>(1)</sup> to obtain dispersion curves for phononic surface waves in two-dimensional phononic structures with general anisotropy in piezoelectric materials.

The explicit formulations of the plane harmonic surface wave dispersion relations in such a general phononic structure are derived based on the plane wave expansion method (PWE). For anisotropic materials, we are interested to calculate the dispersion curves for a triclinic symmetry. We take the piezoelectricity and electrical excitation conditions into account, this work is to investigate theoretically the characteristics of the surface acoustic waves in two-dimensional

# ANALYTICAL AND NUMERICAL STUDY CONCERNING THE BEHAVIOUR OF SINGLE-SIDED BONDED PATCH REPAIRS

Adriana SANDU, Marin SANDU, Loredana TERZEA, Gheorghii OPAȚCHI  
“POLITEHNICA” University of Bucharest, Splaiul Independenței 313, 060042, Bucharest, Romania  
agsandu@yahoo.com

**Abstract.** *Adhesive bonded joints are used in the assembling of structural parts, especially of those which are made from dissimilar materials. Lightweight fibre reinforced polymer composites and other adhesive bonded components represent a major proportion of a modern aircraft. Bonded patch repair technology has been widely used to repair cracked thin-walled structures to extend their service life, because a correctly executed repair significantly enhance the structural performance. In practice, the single-sided bonded patch repair is the most used because a good solution like the double-sided repair may not be an option if the access to the structure is only available from one side.*

*In this paper is presented a relatively simple and effective procedure applied to design the single strapped bonded joints. Also, the influence of various geometrical parameters of the joint is evaluated. The analytical development is validated based on nonlinear finite element analyses.*

**Key Words:** *analytical and numerical study, single-sided patch repairs, design procedure*

## 1. INTRODUCTION

The most important loadings of an aircraft structure are induced by the fatigue cycles due to various fluctuant stresses induced first of all by the cabin pressurizations and in the take-off and landing stages.

In these conditions it is inherent that crack, impact, and corrosion flaws develop throughout the substructure elements and the external cover of the aircraft.

The repair technique by using bonded composite doublers offers maintenance facilities to safely extend the lives of the aircrafts [1]. During the last decades, adhesive bonding has been widely used to construct and repair advanced structures, especially in the aircraft and automotive fabrication.

The main advantage is the possibility to join parts from dissimilar materials as polymers, polymeric composites, aluminium, magnesium or other metal alloys. Bonded structures have been shown to be far more fatigue resistant than equivalent mechanically fastened structures. They are also low-priced and lighter due to the absence of fasteners and easier inspected by using nondestructive techniques.

The mechanical strength of adhesive bonded joint is strongly dependent on the adhesive properties, but the configuration of the joint and the bonding technique are also important. Correct evaluation of the in service behaviour of adhesively bonded joints is necessary to ensure the efficiency, safety and reliability of this kind of assembling [2]-[8].

In many aircraft repairs the most used practical joint configuration is the single-strap joint because the access is only available from the external side of the structure.

Usually, to repair a locally damaged structure, the patch is used to bridge a crack or to cover over a hole.

One of the objectives of paper [7] was to deny the statement that a single-strapped joint is less efficient than the single-lap joint.

This task was accomplished through a detailed analytical and numerical investigation of the joint parameters that govern the peak stresses in the adhesive.

If the outer adherends and the inner adherend (strap or patch) have the same tensile and bending stiffness, the joint is so-called balanced.

In paper [7] the deformations of a typical unbalanced single-strapped joint were determined analytically and subsequent used to calculate the bending moments and the shear forces at the two ends of the overlap, that affect the peak stresses in the adhesive.

In the case of a balanced single-strapped joint, closed-form solutions were obtained, but for an unbalanced joint the two differential equations are coupled and the solution can only be obtained numerically.

It must be pointed out that thermally induced stresses are added to the stresses caused by a mechanical load. They can therefore lead to early failure in certain cases even if their amplitude is



# AN ANALYTICAL SOLUTION FOR DIFFERENTIAL EQUATION OF A COMPOSITE PLATE

Ion FUIOREA\*, Iuliana SPRINȚU\*\*

\*Institute for Theoretical&Experimental Analysis of Aeronautical Structures  
ifuiorea@yahoo.com

\*\*Military Tehnical Academy, sprintui@yahoo.com

**Abstract.** In the previous edition of the AEROSPATIAL Conference (2008) a new differential equation was presented for composite plates as well as the corresponding mathematical models for different boundary conditions. As a natural follow-up, the purpose of the present study was to explore and subsequently establish a technique for determination analytical solutions for the equation. The considered reasons for the solutions were to exactly satisfy the boundary conditions and to verify as close as possible the differential equation of the plate. The weighted residue method was considered to optimise the chosen analytical solutions. Interesting evaluations were performed for different types of functions, especially with respect to the orthotropic answer of the plate. Finally, the purposed solutions were critically analysed considering a FEM solution for comparison.

## 1. INTRODUCTION

This paper aims to find an analytical solution for partial differential equations with corresponding flat plate composites and comparing the results with the numerical solution.

We accept as working hypotheses to determine the constitutive equation of composite flat plate, assumptions of Kirchhoff-Love, extended as follows:

1. During deformations, the normal to the median of the plate remain straight and normal to the deformed middle surface ( $\gamma_{xz} = \gamma_{yz} = 0$  wich implies  $\tau_{xz} = \tau_{yz} = 0$ ). Although efforts unit  $\tau_{xz}, \tau_{yz}$  are very small compared with the normal, we extend the assumption

considering their gradient high enough  $\frac{\partial \tau_{xz}}{\partial z} \neq 0, \frac{\partial \tau_{yz}}{\partial z} \neq 0$ .

2. During deformation of the plate its thickness is constant, equivalent with  $\varepsilon_z = 0$ .
3. We accept the hypothesis of small strains, wich approximates:

$$\varepsilon_x = -z \cdot \frac{\partial^2 w}{\partial x^2}, \quad \varepsilon_y = -z \cdot \frac{\partial^2 w}{\partial y^2}, \quad \gamma_{xy} = -2 \cdot z \cdot \frac{\partial^2 w}{\partial x \partial y}.$$

## 2. DIFFERENTIAL EQUATION OF A COMPOSITE PLATE WHEN THE FIBERS ARE AT AN ANGLE $\theta = 0^\circ$

In the particular case for composite boards when the fibers are at an angle  $\theta = 0^\circ$ , we obtain the partial differential equations:

$$Q_{11} \cdot \frac{\partial^4 w}{\partial x^4} + Q_{22} \cdot \frac{\partial^4 w}{\partial y^4} + 2 \cdot (Q_{12} + 2 \cdot G_{12}) \cdot \frac{\partial^4 w}{\partial x^2 \partial y^2} = \frac{12 \cdot p}{h^3}, \quad (1)$$

where  $Q_{11} = \frac{E_1}{1 - \nu_{12} \cdot \nu_{21}}, \quad Q_{22} = \frac{E_2}{1 - \nu_{12} \cdot \nu_{21}}, \quad Q_{12} = \frac{\nu_{12} \cdot E_2}{1 - \nu_{12} \cdot \nu_{21}}$ .

Equation (1) is a generalization of Sophie-Germain equation .

For example, we consider a flat plate  $300 \times 150 \times 3$  (noting:  $a = 300$  mm,  $b = 150$  mm,  $h = 3$  mm), material: glass fiber/ epoxy with  $E_1 = 2,361 \cdot 10^4$  MPa,  $E_2 = 16,35$  MPa,  $G_{12} = 3115$  MPa, Poisson ratio  $\nu_{12} = 0,159$ , and boundary conditions: the acting pressure  $p = 0,01$  MPa uniformly distributed, plate fixed on long edges and simply supported on short ones.

# EFFECTS OF EPOXY AND PHENOLIC POLYMERS ADDITIVATED WITH CARBON NANOTUBES AND NANOSTRUCTURED SILICATES ON THERMO-MECHANICAL, TRIBOLOGICAL AND RHEOLOGICAL PROPERTIES

<sup>1</sup>Ana STAN, <sup>2</sup>Ion DINCĂ, <sup>1</sup>Adriana ȘTEFAN, <sup>3</sup>Lavinia GAVRILĂ FLORESCU,  
<sup>4</sup>Liviu DUMITRACHE, <sup>4</sup>Horia PAVEN

<sup>1</sup>National Institute for Aerospace Research "Elie Carafoli", Iuliu Maniu 220 Bd., Bucharest, Romania, anastan@incas.ro

<sup>2</sup>Aerospace Consulting, Iuliu Maniu 220 Bd., Bucharest, Romania

<sup>3</sup>National Institute for Lasers, Plasma and Radiation Physics, Laser Department, P.O.Box MG-6, Bucharest, Romania

<sup>4</sup>Institute of Chemical Research, 202 Splaiul Independentei, CP 15-159, 76250 Bucharest, Romania

**Abstract.** *The exceptional properties of carbon nanostructures (carbon nanotubes, carbon nanofibres, carbon black) propose their use in a polymeric matrix to produce nanocomposites with enhanced rheological, mechanical and tribological properties. The main objective of the development of nanocomposites is to transfer the unique properties of carbon nanostructures to polymer matrix.*

*Nanocomposites are synthesized by dispersing inorganic exfoliated nanostructured materials (carbon nanotubes, nanoclays) into polymer matrix.*

*Because of the stiffness of carbon nanotubes, they are ideal candidates for structural application, for example high strength, low weight and high performance composites.*

*Composites of epoxy resin mixed up with different nanoadditives were prepared.*

*The rheological, mechanical and tribological properties of the material were studied experimentally.*

*As polymer, epoxy and phenolic resin and as fillers single and multi-wall carbon nanotubes, carbon nanofibers and montmorillonite, (1%, 2%, 5% by weight) were used.*

*Ultrasonic methods were used to disperse nanofillers.*

## 1. INTRODUCTION

The Nanocomposites 2000 conference has revealed clearly the property advantages that nanomaterial additives can provide in comparison to both their conventional filler counterparts and base polymer.

Properties which have been shown to undergo substantial improvements include:

- Mechanical properties e.g. strength, modulus and dimensional stability
- Decreased permeability to gases, water and hydrocarbons
- Thermal stability and heat distortion temperature
- Flame retardancy and reduced smoke emissions
- Chemical resistance
- Surface appearance
- Electrical conductivity
- Optical clarity in comparison to conventionally filled polymers [1]

The properties and applications of carbon nanotubes (CNTs) and related materials have been very active research fields over the last decade [1–3]. CNTs possess high flexibility, low mass density, and large aspect ratio (typically >1000), whereas predicted and some experimental data indicate extremely high tensile moduli and strengths for these materials. Individual single-walled carbon nanotubes (SWCNTs) can be metallic or semiconducting. [2]

The synthesis of polymer nanocomposites is an integral aspect of polymer nanotechnology. By inserting the nanometric inorganic compounds, the properties of polymers improve and hence this has a lot of application depending upon the inorganic material present in the polymers. In this article we present different types of polymer composites, characterisation techniques and different applications of polymer composites.

## 2. EXPERIMENTAL

### 2.1 Materials

Carbon nanopowders obtained by laser-induced pyrolysis of hydrocarbon-based mixture [2] and natural layered silicate (Cloisite type, an organically modified montmorillonite), considered able to

# STRUCTURAL CHANGES INDUCED BY EXTREME TEMPERATURES IN MULTILAYER CERAMIC STRUCTURES

Adiana ȘTEFAN<sup>1</sup>, Sorin DIMITRIU<sup>3</sup>, Victor MANOLIU<sup>2</sup>, Dionezie BOJIN<sup>3</sup>,  
Gheorghe IONESCU<sup>1</sup>, Constantin VÂLCU<sup>4</sup>

<sup>1</sup>INCAS - National Institute for Aerospace Research "Elie Carafoli", Iuliu Maniu 220 Bd.,  
Bucharest, Romania, adiana@incas.ro

<sup>2</sup>Aerospace Consulting, Iuliu Maniu 220 Bd., Bucharest, Romania

<sup>3</sup>"POLITEHNICA" University of Bucharest, Romania,

<sup>4</sup>National Research and Development Institute for Gas turbine COMOTI SA, Iuliu Maniu 220D,  
Bucharest, Romania

**Abstract.** *The structural changes induced by the thermal factor especially thermal cycling could affect the stability of the thermal barrier coatings.*

*The main research directions are represented to the achievement of new multilayer solutions with extreme thermal properties (temperature, thermal shock and thermal barrier) associated to the functional conditions.*

*It will analyze dynamic structural changes of multilayered materials developed thermal shock tests.*

*Structural bond formed between the ceramic and the metal layer, where air plasma spray metallization leads to adherent deposition, dense and smooth structure with thickness of 0.2 to 2-3 mm depending on application. Thermal shock-induced morphostructural changes on the interface of the developed protection system which will be highlighted by electron microscopy.*

*Interesting are also the method and installation of quickly thermal shock conception and achieved by the authors to evaluate materials in extreme thermal conditions corresponding to the operation of industrial parts in a short period of time, for example turbojet, co-generative systems, etc.*

## 1. INTRODUCTION

TBC concept - thermal barrier coatings is very important for aerospace industry because the mechanical properties of super alloy are maintained and protected against high temperatures due to a low coefficient of thermal conductivity of the ceramic layer.

The performances and endurance of thermal barrier coatings depend on a variety of factors in relation to specific applications.

Thermal conductivity, microstructure, mechanism of destruction and various applications show a real interest.

One of the problems faced by the protection systems is mechanical stress accumulation, induced by thermal gradients that occur at the interface ceramic layer / bonding layer, phase transformations, bonding layer oxidation [1].

Structural changes induced by thermal shock may affect the structural stability of thermal barrier coatings.

Thermal shock is the heating of the samples from tens of degrees temperatures at hundreds of degrees temperatures in a short time (approx. 1 min) and vice versa the cooling of the samples from high temperatures (hundreds of degrees) at low temperatures (tens of degrees).

The thermal shock test aims to reveal micro structural changes of samples shocked; loss of mechanical strength of the coatings as well as the number of shocks the sample resist without suffering damage, i.e. cracks or major exfoliation.

It was considered that the coating material did not resist at thermal shock when appeared obvious cracks or exfoliation in thermal barrier layer.

Thermal barrier is achieved by applying a protective layer with low thermal conductivity and high temperature fusion. [1]

The alloy is protected against high temperatures due to the poor thermal conductivity of ceramics and the thermal expansion compatible with the metal substrate.

Thermal barrier thickness in the range 125 ÷ 500 microns proved to be very important when it comes to protecting turbine.

The mechanism of layers exfoliations is given by the accumulation of residual stresses during the heating cycle and different expansion coefficients of the layers. The tensions can be reduced depending on these coatings.

To improve high temperature strength and thermal shock of metal support, the obtaining method of ceramic thermal barrier layer is to deposition layers containing ZrO<sub>2</sub>·Y<sub>2</sub>O<sub>3</sub> particles.

## Torsion in Thin Walled Hollow Sections

Marcel STERE

INCAS - National Institute for Aerospace Research "Elie Carafoli",  
Bdul Iuliu Maniu 220, Bucharest 061126, Romania, sterem@incas.ro

**Abstract.** The classical theory of elastic thin-walled beams of (assumedly) no deformable cross section, familiar to aerospace engineers, is applied to the torsion of multi-cell profiles. Structural sizing on predesign level using a thin-wall multi-cell beam. This approach is well suited for conceptual design phase. The code is applicable to a multi-cell section with an arbitrary number of webs. We treat the case in which torsion member is made of a linearly elastic isotropic material.

**Key Words:** Bredt\_Batho formula, stress analysis, torsion, thin walled hollow sections, shear flow, software

### 1. INTRODUCTION

Thin-walled elastic beams (single-cell or multi-cell) is a basic problem in the stress analysis of aerospace structures (See Figure 1). But similar problems we met at the bridges (Figure 2), ships (Figure 3), metallic structures, etc. Thin-walled structures have gained a growing importance due their efficiency in strength and cost.

Problems involving torsion are common in aircraft structures. The material covered airplane wing and fuselages are basically thin walled tubular structures and are subjected to large torsional moments in many flight and landing conditions and a knowledge of torsional stresses and distortions of components is necessary in aircraft structural design.

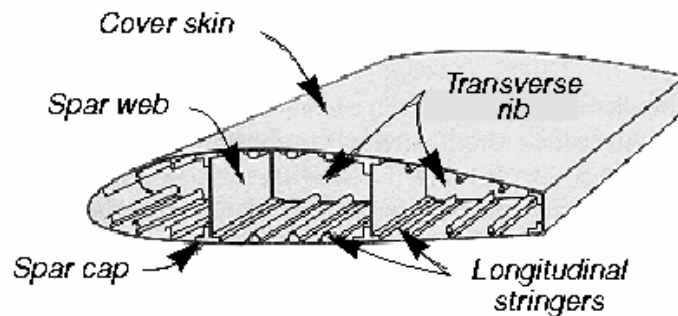

Figure 1 Classical wing (multi-cell box)

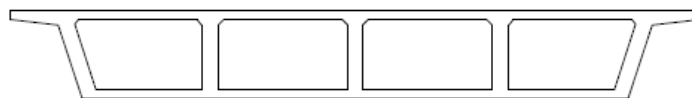

Figure 2 Multi-cell box girder

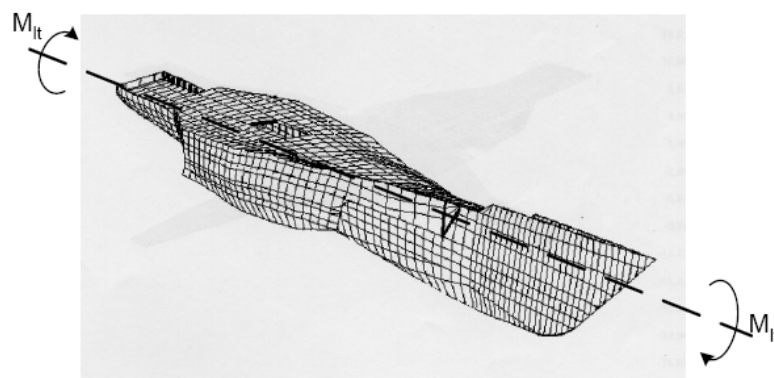

Figure 3 Longitudinal torsion of the ship

In thin-walled beams the wall thickness is assumed to be much smaller than a representative dimension of the cross sections (f.i. chord)  $t/c \ll 1$ .

Consider a thin-walled shell structure of arbitrary constant cross section as shown in Fig.4. The area bounded by the outer wall is subdivided into an arbitrary number of cells, which are

# IMPACT ANALYSIS OF AN AIRCRAFT WITH A SMALL SOLID BODY DURING FLIGHT

Florian VLĂDULESCU, Constantin CIOLOFAN  
INAS SA CRAIOVA, florinv@inas.ro, ciolofanc@inas.ro

**Abstract.** Collisions during flight between aircrafts and small solid bodies may have serious consequences on the lives of on-board passengers and crew flying.

How serious the impact can be and what are its consequences clearly depends on where the contact occurs. We have therefore several situations to take into account:

- the small solid body hits the windshield – the laminated glass will crack or break, the visibility will decrease and the lives of passengers and crew will be at risk.
- the small solid body is "drawn" by the engines – the propeller's irreversible shutdown risk is higher with the increase of the body size and the speed of the jet engines.
- the small solid body occurs in the fuselage – the effect of collision will be a deformation proportional with the body mass and the speed of the aircraft.

This study aims to briefly present the applicability of numerical analysis for the case where there's a collision between a small solid body and the right side of the fuselage coating.

There are many software packages which can be used for this study; the software used for this specific case is ANSYS Workbench which integrates several modules/ applications that allow the user to create the geometry, to generate the mesh and to set-up and solve different dynamic analysis using implicit or explicit solvers.

For a more detailed study of the above case there was performed a numerical analysis using the AUTODYN explicit solver, integrated in the Workbench platform.

The solution will run in Explicit Dynamics and AUTODYN modules, giving the user the possibility to study many cases of hypothetical collisions.

**Key words:** Flight safety, ANSYS Workbench, explicit dynamics, crash/ impact simulation, aerospace technologies

## GENERAL CONSIDERATIONS

This study aims to analyze some situations of impact between aircrafts and small solid bodies, the effects of these collisions and to establish the hazard of collision in terms of both passengers safety and integrity of the aircraft, to increase air transport security.

The number of such collisions was very high in the last two decades, significant damage resulting in the military and civil aviation.

Collisions between aircraft and small bodies occur at low altitudes (which coincides with the time of takeoff or landing of the aircraft).

The risk of such collisions for commercial aircraft at cruising altitude (which vary according to the aircraft type, but generally between 6000-11000 m) is very low, almost non-existent because these small bodies can not be found at these altitudes.

The risk increases after reaching an altitude of 1500 m (near airports), about 61% of these collisions taking place at altitudes below 3000 m.

External structures of modern aircraft must be able to withstand the impact of such bodies and to deform slightly so that aircraft can fly normally.

How serious an impact between a small solid body and an aircraft can be and what are its consequences clearly depends on where the contact occurs. Thus if the strike occurs in the back of the fuselage (common situation), the collision effect is represented by its deformation and is proportional to the mass and velocity of the body that hits the aircraft.

This study intends to briefly present the applicability of numerical analysis, using the ANSYS Workbench program, for various cases of collisions between aircrafts and small solid bodies encountered during flight.

We have created in Geometry (Design Modeler) module the 3D model representing the fuselage coating and the small solid body to which the fuselage comes into contact. Based on the created geometry was then generated the finite element model using an explicit mesh type. The mesh model was generated in the Explicit Dynamics (STR) module, where the numerical analysis included in the present paper was done.

Beside the studies done in the Explicit Dynamics (STR) module, some cases have been also studied in AUTODYN module, the difference between those being that the small solid body which comes in contact with the fuselage coating was approximated by SPH particles (Smoothed Particle Hydrodynamics) in AUTODYN.

## **SECTION 5. Systems, Subsystems and Control**



# ATTENUATION OF SOUND EMISSIONS OF TURBOFAN AIRCRAFT ENGINES

Ștefan BALINT<sup>1</sup>, Agneta M. BALINT<sup>1</sup>, Mirela DARAU<sup>1,2</sup>

<sup>1</sup>West University of Timisoara, stefanbalint@gmail.com,

<sup>2</sup>Technical University of Eindhoven

**Abstract.** In this paper the attenuation of sound emission of turbofan aircraft engines in the Pridmore-Brown model is analyzed.

**Keywords:** aero-acoustics; aircraft noise prediction

## 1. INTRODUCTION

For an acoustically lined inlet and by-pass duct of a turbofan aircraft engine, a mathematical model was built up by Pridmore-Brown [1], in order to describe the sound propagation in the mean flow. Here we speak about the sound propagation produced by an instantaneous, spatially localized acoustic perturbation of the mean flow, or by a time harmonic acoustic perturbation of the mean flow due to the fan-rotor.

The model is a simplified one, corresponding to the particularly simple case when the sound propagates in a fluid, which is flowing between two parallel walls, as it is shown in Fig.1.

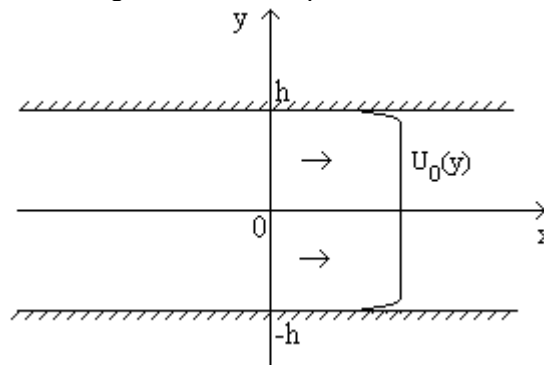

Figure 1. Flow between two parallel walls.

The mean flow velocity profile  $U_0(y)$  is assumed to be approximately constant throughout a central region between the walls and to fall to zero within the two boundary layers. Moreover, the mean velocity profile is assumed to be symmetric about a centre line drawn midway between the walls (see Fig.1).

The boundary condition imposed to the sound wave is that the normal component of the particle velocity (in a direction perpendicular to the wall) vanishes at the wall surface and at the top of the shear layer (the wave matches smoothly on the plane wave above the layer). In this framework two cases are analyzed. The first is the simplest case of perfectly rigid sidewalls and constant gradient of flow velocity.

The second is the case of turbulent flow profile in which the flow velocity increases as the one-seventh power of the distance from the wall. For both cases representative curves are given showing the variation of the sound pressure across the duct, which is brought about by the presence of the flow gradient.

Finally, the effect of the shear flow on the attenuation of the sound when the walls have a small admittance is analyzed. It is shown that the flow has two contrary effects on the sound transmission.

In the first place (for downstream propagation) it tends to increase the absorption by directing sound into the walls.

On the other hand, for wavelengths long compared to the shear layer thickness, this refraction by the flow gradient becomes quite negligible and may in fact be counterbalanced by the increase of intensity in the central region.

The propagation and attenuation of sound in lined ducts containing uniform or ‘plug’ flow, were analyzed theoretically by Tester in [2].



# UNMANNED AIRCRAFTS AND GUIDED MISSILES, CONFIGURATIONS, TECHNICAL SOLUTIONS, PERFORMANCES

Teodor-Viorel CHELARU<sup>1\*</sup>, Nicolae MARIN<sup>2\*\*</sup>, Adrian CHELARU<sup>3\*</sup>

\*"POLITEHNICA" University of Bucharest, teodor.chelaru@upb.ro

\*\*INCAS - National Institute for Aerospace Research "Elie Carafoli" Bucharest

**Abstract.** *The paper proposes a short presentation of the aircrafts with automatic flight, of both classes: UAV and the missiles or guided bombs. Are reviewed major constructive solutions, their advantages and disadvantages, logical choice of solutions and aerodynamic shape. The presentation is exemplified by technical achievements and various projects which are in stages of research and development.*

## TERMINOLOGY

By using the term mobile (M) we define a generic flight device, as an object of the guidance commands, and by using the term target (T) we define a fix or a mobile element, positioned on the ground, in the air or in water in terms of which the aircraft performs, during the guidance process, approaching maneuvers.

The carrier (A) is also a fix or a mobile element positioned on the ground, in the air or in water, which actively participates on the guidance process.

In the kinematical analysis of the guidance methods, the mobile, the target and the carrier, reduced on their centers of mass, will be considered simple points, and the positions and the movements of the target and the carrier, as a system input values, will be considered to be known.

For describing the position and movement of the aircraft as a result of the commands defined by the guidance method and the functional blocks which actively participate at the guidance process, accordingly to [1], [9], we use the term CONTROLLED AIRCRAFT SYSTEM -CAS.

The notion that we must define is that of "the control", which, accordingly to [9], is an automatic process within which the aircraft accomplishes his flight mission.

## 1 INTRODUCTION

This paper's intention is to exemplify the main types of guided aircraft, along with their technical solutions, starting from a couple of aircrafts that were researched in the country after 1981. For a complete classification we also took into account the aircrafts developed in URSS, France and Israel, that were or still are used in the country.

The presentation will be structured on two main classifications, inspired by paper [1], classifications that later have been developed in papers [4],[5] and in the standards [8],[9]. The terminology used is also in line with papers [4],[5], having the standards [8],[9].

## 2 CONTROLLED AIRCRAFT SYSTEM

Accordingly to [9] the notion of "control", the term "Controlled aircraft system" is defined as following:

Controlled aircraft system is an automatic multivariable system, non-linear, in a closed loop, with continuous or discrete functional blocks, which describes the *controlled* flight of the aircraft.

The functional scheme for CAS is indicated in figure 1.

The state variables that describe CAS are state variables for the devices and for controlled flight that describe the position and the movement of the aircraft:

- State variables that describe the functioning of the blocks contained in the command system;

- State variables that describe the position and the relative movement of the aircraft – carrier-target accordingly to the guidance methods described by two or three items.

---

<sup>1</sup> PhD, Assoc. Prof.

<sup>2</sup> PhD

<sup>3</sup> Student

# Free Flight vs. Centralized Air Traffic Management

Bogdan DONCIU<sup>1</sup>, Octavian Thor PLETER<sup>2</sup>

“POLITEHNICA” University of Bucharest, Faculty of Aerospace Engineering

Spl. Independentei 313, 060042 Bucharest, Romania, octavianpleter@yahoo.com

**Abstract.** *The current Air Traffic Management system is subject to structural changes, which are expected over the next 20 years. These changes are required for a number of reasons:*

- *The current system inflicts delays and fuel inefficiencies to flights (as demonstrated by the historic Paris-Miami Air France flight in April 2010)*
- *The current system has structural and operational capacity limitations*
- *Under current system, the complexity of the Air Traffic Controller’s work increases steeply with traffic*
- *Voice communication on a single radio frequency in ATC is limitative and subject to errors*
- *Safety is sometimes jeopardized and separation relies on a safety net (ACAS)*
- *The introduction of the ACAS systems as a separation safety net presents a structural risk in the classic ATC philosophy (as demonstrated by the Überlingen 2002 mid-air collision)*
- *ATM is the only system left in Civil Aviation, with virtually no automated core process*

*There is a major choice to make for the future Air Traffic Management automation in both NextGen and SESAR programs: the free flight concept, and the opposite, the centralized management. This paper is an assessment of both scenarios, and their implications for traffic capacity, air traffic control complexity, safety and efficiency.*

## 1. INTRODUCTION

The classic Air Traffic Control in effect today relies on the human controller, who is responsible for the aircraft separations at all times, by tactical control actions.

There are several limitations to this classic approach, which made the aviation community to find options to replace the current system with something else.

These limitations are well documented in the literature (Erz95), (Pre03), (Ple04), (Gra09):

- Voice-based link restricts capacity, due to the time consumed by every tactical action (voice communication frequency congestion);
- Voice-based link is more vulnerable to errors, in spite of the read-back rule;
- Air traffic complexity, workload and communication frequency usage are variable over time, causing both inefficiencies due to lack of traffic, and delays due to exceeded capacity;
- Traffic capacity for a given sector is limited by the maximum number of aircraft using the services, because the span of attention of a human controller is limited;
- Reducing the size of the sectors is also limited by the hand-over protocols, which occupy an increasing share of the communication frequency;
- Inefficient flights, due to decisions which do not account for impact on downstream sectors, and which lack important pieces of information, such as aircraft performances.

For these reasons, adopting a new approach to air traffic management is imminent in the medium to long term, and this approach has to be based on a solution which should be chosen in the near term.

This paper is taking a number of ideas and tests in this field, discriminating them with respect to the fundamental question of decision making centre.

## 2. DECISION-MAKING CENTRE DISCRIMINATOR

There are two classes of solutions to the future air traffic management problem, based on opposed principles:

- *Free-flight* solutions, which use new technology to enable pilots to decide how to avoid each other; ACAS<sup>3</sup>/TCAS<sup>4</sup> systems are precursors of this concept, already in use;

---

<sup>1</sup> PhD student in Aerospace Engineering of UPB-FIA, general director of Romanian Air Traffic Services Administration

<sup>2</sup> PhD in Aerospace Engineering and in Economic Sciences, associate professor at UPB-FIA

<sup>3</sup> Airborne Collision Avoidance System (ICAO)

<sup>4</sup> Traffic Collision Avoidance System, an American ACAS implementation currently in use

# Analysis of the Miniaturized Inertial Sensors Stochastic Errors with the Allan Variance Method: A Review

Teodor Lucian GRIGORIE, Mihai Aureliu LUNGU, Ioana Raluca EDU, Radu OBREJA  
 University of Craiova, Faculty of Electrical Engineering, Avionics Division, Romania  
 lgrigore@elth.ucv.ro

**Abstract.** *The paper is a review of a method to evaluate the inertial sensors stochastic errors in order to be used in the improvement of the sensors' signal-to-noise ratio, but also in the removing of the sensors errors that are mixed with the motion dynamics of a vehicle navigated by using a strap-down inertial system. After a brief description of the Allan variance, the main types of inertial sensor stochastic errors are reviewed. Further, the representation of quantization noise, angle random walk, bias instability, rate random walk, sinusoidal noise, and drift rate ramp in Allan variance is performed. Finally, the sample plot of Allan variance for each type of inertial sensors stochastic error and the analysis methodology are presented.*

## 1. INTRODUCTION

The demand of navigation and guidance has been urgent for many years. Nowadays, the control of flight dynamics is based on the use of Inertial Navigation Systems (INS). Also, the Inertial Measurement Units (IMUs) are widely used in problems regarding aeronautics, space technology, marine problems, and so on. IMU consists of accelerometers and gyros for measuring angular velocities and accelerations in three dimensions ([1]-[5]).

The major impact of sensors' miniaturization technologies on the equipments and systems in aerospace engineering field was fully manifest in the strap-down inertial navigators. Thus, inertial sensors have been made (accelerometers and gyros) based on the MEMS (micro-electro-mechanical systems), NEMS (nano-electro-mechanical systems), MOEMS (micro-opto-electro-mechanical systems), and NOEMS (nano-opto-electro-mechanical systems) technologies. Inertial sensor miniaturization advantage, however, was in part overshadowed by obtaining of poor performances reflected by the high level of noise and by its direct filtration failure due to spectral overlap with the sensor input considered useful in terms of frequency for navigation applications ([2], [5]-[7]).

For accelerometers and gyros there are existing errors that cause unacceptable drifts and bias. The noises in these systems are categorized as stochastic errors. In addition to stochastic errors, miniaturized inertial sensors are affected by deterministic errors, but which can be estimated and compensated relatively easily by classical calibration methods ([2], [5]-[7]).

A simple model for these sensors was presented in [6]; here the authors have made a classification of the common errors found in accelerometers and rate gyros into three categories: a constant offset error source, a moving bias error source and a random error source.

On the other way, the new sensors models incorporate errors affected by the true accelerations or rotations rates: scale factor error, misalignment error, and non-orthogonality error ([1], [4], [7]-[16]).

Usually, the errors of the inertial sensors can be can be classified into the following categories: bias, scale factor error, axes misalignment, and noise.

The bias of accelerometers or gyros is the average over a specified time of accelerometer/gyro output, measured at specified operating conditions that have no correlation with input acceleration or rotation ([17]). The measurement unit for gyros' bias is deg/h or rad/s, while the measurement unit for accelerometers bias is  $m/s^2$ . The bias has two parts: the bias offset (the deterministic part of the bias), which refers to the offset in the measurement and that can be determined by calibration, and the bias drift (the random part of the bias) which refers to the rate at which the error in the inertial sensor accumulates time ([17]).

The sensor scale factor is the ratio of change in the input intended to be measured (the slope of the line obtained with the least squares method to input-output data). This kind of error is a deterministic one and can be determined by calibration. The scale factor may also be characterized (described) by the scale factor stability – the capability of the sensor to accurately sense angular velocity or acceleration at different angular rates of accelerations ([17]).

The error that results from the imperfection of the sensors' mounting is called the axes misalignment error. Each axis is affected by the measurements of the other two axes in the body frame. This kind of error may be compensated or modeled in the INS error equation ([17]).

## DATA ENCRYPTION SOLUTION FOR SECURED RADIO COMMUNICATIONS WITH MINI UAV- SACT BOREAL5

Gheorghe GUIMAN, Gigi-Daniel BUDARIU, Gabriel TÂRȘA, Ionuț RĂDOI  
Military Equipment and Technology Research Agency, Bucharest, Romania  
gbudariu@acttm.ro

**Abstract.** Currently, communication with mini UAV-SACT Boreal5 is made through AC4490 transceiver module using (as feature) a DES 56-bit encryption solution, which is totally not acceptable for sensitive communications in military environments. The need to protect data exchange became important due to the lack of a secured communication channel between ground devices and mini UAV. This paper shortly presents a solution to secure the communication channel using latest encryption standards and recommendations. Basic features including authenticity, integrity and confidentiality assure the protection of packets using AES-CCM (Advanced Encryption Standard – Counter and CBC- MAC mode) encryption algorithm (at physical level) and IKE (Internet Key Exchange) for key management. This solution runs on a XILINX FPGA hardware platform as an additional module, inserted in the data transmission chain between modem and sensors/commands block, both at ground devices and mini UAV.

### 1. INTRODUCTION

In modern warfare, success on the complex networked battlefield is based on proper data collection, fusion and interpretation. Until recently, surveillance and reconnaissance meant that multi- million satellites or surveillance airplanes were used to gather data over hostile territory. Nowadays, the surveillance and reconnaissance field is dominated by a much more cost effective solution that presents no risk to the operators: the Unmanned Aerial Vehicles. Because of their advantages, characteristics and capabilities, the role of Unmanned Aerial Vehicles (especially mini versions) as data collection platforms has increased exponentially. Thus the development of UAVs has also known a very rapid evolution.

### 2. MINI-UAV SACT BOREAL 5 SYSTEM

The mini-UAV SACT BOREAL 5 system, shown in Figure 1, is a mini UAV developed and tested by the Military Equipment and Technology Research Agency. The efficiency/cost rate played a major role in the process of choosing the best technical solution for this platform. Consequently, the platform integrated many COTS (commercial of the shelf) products that were adapted to our specific needs. The objective of this platform is the close range surveillance (< 10 Km) of the tactical field. This platform is a real time data acquisition system that is equipped with specialized sensors like CCD video camera and IR sensors.



Figure 1. General view of SACT BOREAL 5 System

The platform consists of two distinct entities: the ground unit and the aerial unit. The ground unit, presented in Figure 2, includes:

- Notebook Tablet PC Kontron;
- E 2410 Video Receiver;
- AeroComm 4490 Radiomodem.

## Upgrading the Turbojet Engine Test Bench at Aerostar SA

Laurian Tiberiu MOCANU, Alexandru Tristian BALMUȘ, Anton PAL,  
Adrian DUMITRESCU, Ștefan POPA  
Aerostar SA, Condorilor 9 600302, Bacău, Romania, tiberiu.mocanu@aerostar.ro

**Abstract.** *The present paper describes the activities performed in Aerostar SA to improve the turbojet engine test bench in order to get several beneficial effects such as decreasing the fuel consumption for an engine test run with up to 30%, reducing the air pollution and noise emission and increasing the test accuracy and data availability.*

*The original test bench was equipped with a new data acquisition and automatic processing system of the operating parameters of the turbo-jet engine during ground test on the test bench.*

*The system is designed to monitor and record the parameters, to automatically compute the performance parameters in accordance with the test requirements technique, to store the results in a data base, to distribute the data to the local and remote users.*

*The system monitors the engine under test and it is composed by a set of sensors, a data acquisition system, a PC, which runs a software applications package.*

*Data acquired as well as relevant reports are printed on a printer.*

*Images of the engine under test are taken by a set of video cameras which, by means of the video acquisition block reach the computing system.*

*Via the local area network the relevant data are stored on a file server and can be accessed by local terminals or by remote users on the internet.*

### BACKGROUND

Since 1953, Aerostar SA (former URA, IRAv and IAv – BACAU) is a major provider of products, services and support for RoMOD, foreigner Air Forces – including NATO members, Ground Forces, and civil aviation market (industrial and operators), etc.

A prime business field of Aerostar SA is the Overhaul of Turbojet Engines for fighter aircraft with more than 6000 units repaired and delivered to the clients.

The existing Test Bench for Turbojet Engines is 40 years old, built under Soviet design and development supervision at the state of the art of the '70-ies.

The main features of the said configuration:

- Mechanical dial indicators – manual registration on paper based Acceptance Test Report (ATR);
- Dynamic parameters such rapid variation of pressures, vibrations, starter voltage and current consumption and so on, recorded on film in a Flight Data Recorder (FDR) type;
- Fuel flow measurement – gravimetric method i.e. measuring the time the engine consumes a certain fuel quantity ( 100 Kg , 50Kg or 25 Kg depending on the regime), several times during an engine run;
- Manual calculation of indirect and reported parameters such as temperature of the gases, thrust, turbine rate, etc. based on nomograms and formulae;
- ATR and QA documents archived on paper in cabinets.

This complex installation was intensively used when the gas consumption was not a main issue in the era of pollution carelessness.

To make the final adjustments of the turbojet engine after overhaul, the factory acceptance test and, finally, the customer reception test, at least three engine runs must be performed. The total fuel consumption for each engine is several tenths of tones.

Any percentage in fuel consumption cut represents a significant cost reduction considering the increasing price of the gas.

The gas consumption reduction implies the CO<sub>2</sub> emission reduction as well, thus a bigger margin for the total CO<sub>2</sub> emission that Romania may benefit.

## Prediction of Pilot Induced Oscillations

Valentin PANĂ

University “Politehnica” of Bucharest, Faculty of Aerospace Engineering, Str. Polizu, No. 1,  
Bucharest, Romania, valentin\_pana@yahoo.com

**Abstract.** An important problem in the design of flight-control systems for aircraft under piloted control is the determination of handling qualities and pilot-induced oscillations (PIO) tendencies when significant nonlinearities exist in the vehicle description. The paper presents a method to detect possible pilot-induced oscillations of Category II (with rate and position limiting), a phenomenon usually due to a misadaptation between the pilot and the aircraft response during some tasks in which tight closed loop control of the aircraft is required from the pilot. For the analysis of Pilot in the Loop Oscillations an approach, based on robust stability analysis of a system subject to uncertain parameters, is proposed. In this analysis the nonlinear elements are substituted by linear uncertain parameters. This approach assumes that PIO are characterized by a limit cycle behavior.

**Key Words:** aircraft pilot coupling, uncertain parameters, Edge Theorem.

### 1. INTRODUCTION

A pilot induced oscillation (PIO) is a complex interaction between the human pilot and the aircraft that leads to sustained and sometimes very large amplitude oscillations of the aircraft. It is characterized by a loss of stability margin in the pilot-aircraft closed loop system. These oscillations can occur about any of the aircraft's axes of symmetry.

Many flight test accidents and incidents have been attributed to PIO problems. Most recently, both the F-22 and JAS-39 prototypes have crashed as a result of PIO incidents. Commercial aircraft are also not immune to PIO problems (A-320, Boeing 777). The potential occurrence of PIO is amplified by the use of modern control technology including fly-by-wire systems that determine important modification of the airplane response characteristics. For example in heavy aircrafts, the problems result in a faster roll rate than normally expected. This combined with delays introduced by the fly-by-wire system cause PIOs.

Detailed analytical studies of PIO incidents are based on pilot behavioral models and closed loop analysis procedures designed to understand and rationalize the phenomena and their associations. The classification of PIO [15] takes into account some possible different behaviors of the closed loop pilot vehicle system during the PIO. Recently a new category (IV) has been added to account for another type of interaction in the pilot vehicle system.

*PIO Category I* – Essentially Linear Pilot-Vehicle System Oscillations: The effective controlled element characteristics are essentially linear, and the pilot behavior is also quasi-linear and time stationary.

*PIO Category II* – Quasi-Linear Pilot Vehicle System Oscillations with Rate Limiting or Position Limiting: The closed loop pilot vehicle system has a nonlinear behavior, mainly characterized by the saturation of position or rate limited elements.

*PIO Category III* – Essentially Nonlinear Pilot Vehicle System Oscillations with Transitions: These PIO depend on nonlinear transitions in either the effective controlled element or in the pilot's behavioral dynamics.

*PIO Category IV* – Refers to coupling effects between pilot inputs and the aircraft structural modes.

In the present paper an analysis method to predict Category II PIO is considered. These oscillations are induced by nonlinearities determined by rate or position saturations of control surface actuators.

This kind of nonlinearity is present in any aircraft, because of the physical constrains of elements such as stick deflections, actuator position and rate limiters, limiter in the controller software. Actuator rate limiting occurs when the input rate to the control surface exceeds the hydraulic and/or mechanical capability of the control surface actuator. Rate limiting has been identified with PIO for two main reasons.

First, it introduces additional phase lag, or delay, between commanded control surface position and actuator control surface. The time delay caused by the additional phase lag can drive the pilot to compensate with faster inputs, worsening the situation. This can ultimately lead to a PIO or unstable situation.

# MINIMUM TIME CONTROL AND MINIMUM ENERGY PROBLEM FOR LINEAR SYSTEMS IN HILBERT SPACES

Mihai POPESCU

"Gheorghe Mihoc-Caius Iacob" Institute of Mathematical Statistics and Applied Mathematics of ROMANIAN ACADEMY, Calea 13 Septembrie No.13, Sector 5, 050711 Bucharest, PO. Box 1-24, 70700, Bucharest, Romania, ima\_popescu@yahoo.com

**Abstract.** We analyze the existence and uniqueness of the optimal control for a class of exactly controllable linear systems. We are interested in the minimization of time, energy and final manifold in transfer problems. The state variables space and, respectively, the control variables space, are considered to be Hilbert spaces. The linear operator which defines the solution of the linear control system is a strong semigroup. Our analysis is based on some results from the theory of linear operators and functional analysis. The results obtained in this paper are based on the properties of linear operators and on some theorems from functional analysis.

**Keywords:** existence and uniqueness, optimal control, controllable linear systems, linear operator.

**Mathematics Subject Classifications (2000):** 49J15 - 49N05.

## 1. INTRODUCTION

A particular importance should be assigned to the analysis of the control of linear systems, since they represent the mathematical model for various dynamic phenomena. One of the fundamental problems is the functional optimization that defines the performance index of the dynamic product. Thus, under differential and algebraic restrictions, one determines the control corresponding to functional extremisation under consideration [5, 6]. Variational calculation offers methods that are difficult to use in order to investigate the existence and uniqueness of optimal control. The method of determining the field of extremals (sweep method), that analyzes the existence of conjugated points across the optimal transfer trajectory (a sufficient optimum condition), proves to be a very efficient one in this context [8, 9, 12].

Through their resulting applications, time and energy minimization problems represent an important goal in system dynamics [4,7,10,11,13,14]. Recent results for controllable systems express the minimal energy through the controllability operator [1,3,14]. Also, stability conditions for systems whose energy tends to zero in infinite time are obtained in the literature [2,3]. By using linear operators in Hilbert spaces, in this study we shall analyze the existence and uniqueness of optimal control in transfer problems.

The goal of this paper is to propose new methods for studying the optimal control for exactly controllable linear system. The minimization of time and energy in transfer problem is considered. The minimization of the energy can be seen as being a particular case of the linear regulator problem in automatics. Using the adjoint system, a necessary and sufficient condition for exact controllability is established, with application to the optimization of a broad class of Mayer-type functionals.

## 2. MINIMUM TIME CONTROL

### 2.1 Existence

#### 2.1.1 Problem formulation

We consider the linear system  $(\Sigma_{A,B})$ :

$$\frac{dx}{dt} = Ax(t) + Bu(t), \quad x(t_0) = x_0 \in H, \quad (1)$$

where  $H$  is a Hilbert space with inner product  $\langle \cdot, \cdot \rangle$  and norm  $\|\cdot\|$ .

$A: D(A) \subset H \rightarrow H$  is an unbounded operator on  $H$  which generates a strong semi group of operators on  $H$ ,  $(S(t))_{t \geq 0} = (e^{tA})_{t \geq 0}$ .

$B: U \rightarrow H$  is a bounded linear operator on another Hilbert space  $U$ , for example  $B \in \mathcal{L}(U, H)$ .

$u: [0, \infty] \rightarrow H$  is a square integrable function representing the system control (1).

For any control function  $u$ , there exists a solution of (1) given by

# METHODOLOGIES FOR ROBUST CONTROL OF PIEZOELECTRIC SMART STRUCTURES. THEORETICAL AND EXPERIMENTAL RESULTS

Ioan URSU, Lucian IORGA<sup>1</sup>, Adrian TOADER, George TECUCEANU  
 INCAS – National Institute for Aerospace Research “Elie Carafoli”  
 Bd. Iuliu Maniu 220, Bucharest 061126, Romania, iursu@incas.ro  
<sup>1</sup>now at Airbus UK

**Abstract.** Active structural vibration control has become an important research area in the aircraft design in the last decades. In this paper we focus on the particular case of vibratory control of lightweight structures using integral actuation and we focus in particular on the application of robust deterministic control laws. The paper first outlines approaches to the principal problems that the structural control engineer has to address when designing robust control laws: structural modeling techniques, uncertainty modeling and model identification. The well known framework of Riccati equations employed to synthesize two controllers, an  $H_\infty$  controller and an LQG/LTR one. Finally, the basic laboratory architecture for control law validation is presented, with a cantilevered plate equipped with MFC actuators and strain gage sensors serving as paradigm of the smart structure. The experimental results are finally shown to testify the effect of the active control.

## 1. INTRODUCTION

The major components of a typical active structural vibration control (SVC) system are the mechanical structure, on one hand and, on the other, the control system consisting of the actuators providing an energy input into the structure, the controller computing this necessary input and the sensors providing the controller information on the state of the structure. The design of an active SVC is particular to each specific structure considered, but a basic series of steps common to all such designs involves various analyses and simulation steps as outlined in Fig. 1 [1]. Indeed, the design a SVC system is a complicated work, and many issues need to be addressed. For a large scale structure, such as the aircraft wing, complexity of the structure itself makes some of these issues more challenging.

Generally speaking, the vibration control can be achieved by either passive or active methods. Passive vibration control approaches suffer from being ineffective at low frequencies. On the other hand, active control approaches provide numerous advantages; e.g., reduction of size and weight, programmable flexibility of design. Actuators based on the piezoelectric effect are suitable for active vibration control because of their wide frequency range and relatively high actuation forces.

A smart-structure system can be defined as a system that can sense the external stimulus and respond to that stimulus quickly through a control system. Most activities in the smart-systems field have been supported through aerospace and defense agencies.

Conventional automatic control systems with servovalve/hydraulic actuators suffer from several limitations such as (i) multiple energy conversions (mechanical, hydraulic, electrical), (ii) large number of parts, i.e., potential failure sites and large weight penalty, (iii) high vulnerability of the hydraulic network, and (iv) frequency bandwidth limitation. In contrast, smart actuators, such as piezoelectric type, offer unique advantages such as (i) electrical energy is converted directly to high-frequency linear motion, (ii) electrical energy is easier to transmit throughout the structure, and (iii) implementation of smart-materials induced-strain actuation eliminates the need for bulky hydraulic power systems and relies directly on electrical-to-mechanical conversion.

Robust control, founded in 1980's, focuses on the development of controllers that can maintain good performance while parameters of controlled plants incur bounded deviations. Many robust control schemes have been applied to active control of vibration and noise, as well as smart structural systems. In the paper [3], the authors combined LQG type synthesis with robustness and performance analysis to design a vibration controller for flexible aeroelastic modes of the supersonic aircraft. The complex  $\mu$ -synthesis procedure based on D-K iteration was used on the complex structured uncertainty model [4], [5].  $H_\infty$  control for vibration suppression of a plate was used in [6], where the first three modes were considered in the model and the rest modes were treated as uncertainty. The present paper continues previous works of the authors [7], [8], [5],



# UNFALSIFIED CONTROL; APPLICATION TO AUTOMATIC FLIGHT CONTROL SYSTEM DESIGN

Andrei-Sorin NEAM<sup>U1,2</sup>, Adrian-Mihail STOICA<sup>1</sup>

<sup>1</sup>Faculty of Aerospace Engineering, “POLITEHNICA” University of Bucharest, Romania

<sup>2</sup>INCAS - National Institute for Aerospace Research “Elie Carafoli”, Bucharest, Romania  
aneamtu@incas.ro, amstoica@rdslink.ro

**Abstract.** *Unfalsified Control Theory has been developed to provide a way to avoid modeling uncertainties in controller design. It belongs to the class of control methods called Adaptive Supervisory Switching Control, which work by introducing in the control scheme a supervisory unit which chooses, from a set of candidate controllers the one most suited for the current plant. Unfalsified Control works by using a switching logic that dispenses with the need for a-priori knowledge of the dynamic model. At discrete moments of time, using the input/output data recorded up to that point, the supervisory calculates for each candidate controller a performance index, and compares it to a given threshold. Controllers surpassing that threshold are removed from the candidate controller set. This process is called falsification. If the controller in the loop is one such falsified controller it is replaced.*

*In this paper we investigate the suitability of this method for aeronautical control applications. We review the theory behind this control scheme and adapt it to the case of controlling a fighter aircraft. We also provide a case study, where we test this control scheme on a simulated fighter aircraft.*

## 1 INTRODUCTION

Adaptive Control was first introduced in the 1950's in an attempt to alleviate some of the problems in controlling high speed fighter aircraft which often find themselves in conditions which are very hard to model due to their highly non-linear nature, or high number of uncertainties. Despite initial success Adaptive Control soon showed many deficiencies which have confined it solely to research studies.

However, recently, methods have been devised that might make Adaptive Control a reality.

Over the last two decades a lot of research has been put in Adaptive Switching Supervisory Control (ASSC) (see [1], [2], [4], and [9]). ASSC is in fact an adaptive variant of classical gain scheduling, turned, by the use of a supervisory logic based on plant input/output recorded data, from an open loop switching mechanism to a closed loop one.

A typical ASSC is depicted in Figure 1. Where a data driven “high-level unit”  $S$ , called *supervisor*, which controls each plant  $G$  belonging to the given set  $\mathcal{G}$  of plant models by connecting an appropriate controller  $K$  from the set  $\mathcal{K}$  of candidate controllers

The supervisor decides if the currently switched-on controller works properly, and, in the negative case, it replaces it by another candidate controller. The scheduling task (when to substitute the acting controller) and the routing task (which controller to switch on) are carried out in real time by monitoring purely data-driven test functional [1].

The main current approaches to ASSC can be subdivided into two different groups: the first consists of the so called *Multi-Model* ASSC (MASSC), wherein a dynamic nominal model is associated with every candidate controller, the second called *Unfalsified* ASSC (UASSC) [1], [9] wherein a switching logic that dispenses with the need for a-priori knowledge of the dynamic model is used. Both these methods have their advantages and disadvantages.

MASSC schemes work by comparing norms of sequences of estimation errors based on the various nominal models, as the candidate controller associated to the nominal model yielding the prediction norm of minimum magnitude is believed to be the most suitable one.

The main advantage is the fact that transient times before finding a stabilizing controller tend to be small.

However this can be achieved only by using a very dense model distribution. If this condition is not enforced neither convergence to a final controller, nor boundness can be guaranteed.

In contrast UASSC schemes as described by [9], can select in finite time a final controller yielding a finite affine gain from the reference to the data, under the minimal conceivable requirement regarding the existence of a stabilizing candidate controller.

This along with the fact that the plant need not be linear makes this schemes from the robustness point of view much better suited to aerospace applications than MASSC, the asymptotic stability properties of the latter being typically only guaranteed if the unknown plant is

## REDUCING FUEL CONSUMPTION IN BUCHAREST TERMINAL AREA FOR FLIGHTS USING A STANDARD INSTRUMENT DEPARTURE

Alin George DIACONU<sup>1</sup>, Octavian Thor PLETER<sup>2</sup> and Virgil STANCIU<sup>3</sup>

“POLITEHNICA” University of Bucharest, Faculty of Aerospace Engineering,  
Spl. Independentei 313, 060042 Bucharest, Romania  
alin07\_a@yahoo.com

**Abstract.** *Reconfiguration of the standard instrument departure and standard arrival routes at certain airports can bring significant reductions in fuel consumption and level of noise. This can be done either by implementing modern radionavigation aids for terminal areas or by eliminating the flying restrictions over cities and inhabited places and designing of low level of noise procedures for these areas. These solutions have other important benefits like decreasing the workload for the air traffic controllers and reducing the total flight time. The paper describes an operational solution in this manner for Bucharest Henri Coandă International Airport.*

### INTRODUCTION

Standard Instrument Departures are produced with the object of expediting the safe and efficient flow of air traffic operating from the same or different runways at the same or neighbouring airfields. SIDs aim is to deconflict potentially conflicting traffic by the use of specific routings, levels and check points.

Typically, each runway will have a number of SIDs and STARs to ensure that air traffic is not unnecessarily delayed by deviation from the direct route from or to the aerodrome. Although a SID will keep aircraft away from terrain, it is optimized for ATC route of flight and will not always provide the lowest climb gradient, but strike a balance between obstacle avoidance and airspace considerations.

In order to permit all weather operation (low visibility take-off and landing) procedures are established to provide track guidance and terrain avoidance for aircraft departing, and track guidance, terrain clearance and where special equipment is used, vertical displacement guidance for aircraft arriving at aerodromes.

It is implied that any procedure developed will not require aircraft to fly dangerously close to obstacles at any point during the procedure. Clearance from obstacles can be obtained by lateral clearance and vertical clearance. Obstacle clearance can be provided by assessing the highest obstacle to be flown over and by applying a safety margin to the obstacle height.

Departure procedures assume that all engines are operating. The design of an instrument departure procedure is, in general, dictated by the terrain surrounding the aerodrome, but may also be required to cater for ATC requirements (adjacent ATS routes, restricted, danger or prohibit areas).

Where instrument departures are expected to be used, a departure procedure will be established for each runway to be used, and will define the procedure for the various categories of aircraft based on an engines running procedure design gradient of 3.3% or an increased procedure design gradient if required to achieve minimum obstacle clearance.

The procedures assume that pilots will not compensate for wind effects when being radar vectored, and will compensate for known or estimated wind effects when flying departure routes which are expressed as tracks to be made good.

Obstacle clearance is a primary safety consideration in instrument departure procedures. Unless otherwise stated a procedure design gradient (PDG) of 3.3% is assumed. The PDG is made up of 2.5% gradient of obstacle identification surfaces or the gradient based on the most critical obstacle penetrating these surfaces, and 0.8% increasing obstacle clearance.

There are two basic types of departure routes, straight, or turning. Departure routes are based on track guidance acquired within 20Km (10.8NM) from the end of the runway (DER) on straight departures, and within 10Km (5.4NM) after completion of turns on turning departures.

---

<sup>1</sup> PhD student in Aerospace Engineering of UPB-FIA

<sup>2</sup> PhD in Aerospace Engineering and in Economic Sciences, associate professor at UPB-FIA

<sup>3</sup> PhD in Aerospace Engineering, dean of UPB-FIA

# SOME ASPECTS REGARDING THE MODELING OF HIGHLY PRESSURIZED SQUEEZE FILM DAMPERS

Laurențiu MORARU

Department of Aerospace Sciences, "POLITEHNICA" University Bucharest  
Splaiul Independenței 313, 060042, Bucharest, Romania  
laurentiu.moraru@gmail.com

**Abstract.** *Squeeze film dampers (SFD) have been used for many years to control vibration in gas turbines and other high-speed rotating machinery. The overall objective of this paper is to present the analysis and validation of a dynamic model of a highly pressurized squeeze film damper. Predictions based on the model are utilized in the rotordynamic modeling of a rotor supported on a SFD.*

**Key Words:** *Squeeze film dampers (SFD), hydrodynamic bearings, rotordynamics*

## 1. INTRODUCTION

During the last decades, one takes place a continuous and tremendous race of improving the performances of the turbomachinery. Improving the dynamic performances and lowering the specific fuel consumption are permanent goals of engine designers and manufacturers. Turbo machines tend to be lighter and lighter and the clearances thinner and thinner and these led to an increase vibration sensitivity. Much effort and resources have been spent for the development of improved balancing techniques, but sometimes it is not possible to achieve the desired low level of vibrations by balancing alone. Rotor assemblies, though well balanced initially degrade with continuous service time. Consequently, continuous efforts have been continuously made to improve dampers' design.

One of the commonly used types of dampers is the squeeze film damper (SFD). Many theoretical and experimental studies has been dedicated to this type of device but no "standard" satisfactory approach is yet available. This paper presents cases when the classical Reynolds theory was successfully applied to predicting properties of a highly pressurized SFD. The main analytical solution of the short SFD is implemented on an experimental damper. The theoretical unbalance response of a rotor supported on the SFD is compared against the experimental results.

## 2. DESCRIPTION OF THE EXPERIMENTAL SET-UP. THE MATHEMATICAL MODEL OF THE SYSTEM. RESULTS AND DISCUSSIONS

SFDs have been intensively studied during the last decades and an extensive review is beyond the purpose of this paper. Review papers, like, for example, the studies of Moore [1] and Zeidan et. al. [2] present some key information in the field.

For design purposes it is very important to know the values of the forces developed in the damper. The pressures in the oil film can be determined from fluid flow equations. For the classical lubrication conditions, the Navier Stokes equations and the continuity equation can be simplified and combined into the Reynolds equation, which can be solved for the pressure distribution. Continuous efforts have been dedicated to this subject and new numerical methods have been adopted, Refs. [3], [4]. The combined affects of fluid inertia and gaseous phenomena, is still subject of open research.

The order of magnitude of the inertia forces is indicated by the Reynolds number, which, for SFD lubrication is expressed as [5]

$$\text{Re}^* = \frac{\rho \omega c^2}{\mu} \quad (1)$$

Inertia of the oil can be neglected if Reynolds number is smaller than 1 and, consequently (if the gaseous phenomena are also negligible) the forces in the oil film can be obtained from the Reynolds equation.

The effects of fluid inertia have been studied for several decades, Refs. [6] - [8] and many researchers also confirmed the interrelation between the inertia effects and cavitation, Ref. [9].

On the other hand, cavitation in hydrodynamic oil film bearings (the gaseous phenomena which often appears in the divergent are of the bearing) is quite complex and it depends upon the

## **SECTION 6. Experimental investigations in aerospace sciences**



# Synchronized processing of flight test parameters with audio-video information provided by the avionics system of IAR 99 ȘOIM aircraft

Eugen DUMITRU<sup>1</sup>

Research and Flight Test Center, eugendumitru@ftc.ro

**Abstract.** The instrumentation of IAR 99 SOIM aircraft permits, via ACRA system, the recording of a wide variety of flight test parameters that are provided by transducers, by MUX- BUS MIL STD 1553B and also the recording of the audio and video information provided by the avionics system. This paper presents application software for the synchronized processing of the complex information recorded by ACRA system. The application software permits the synchronized visualization of each parameter evolution and can export the evolution of each parameter in common files, for each test sequence.

## INTRODUCTION

To process the complex data records by the ACRA system it was developed an application software in Visual Studio IDE. The software permits the following function:

- Processing the flight data provided by the ground station of ACRA system
- Processing the flight data recorded from MUX- BUS MIL STD 1553B
- Synchronized visualization of avionics audio-video recorded also by ACRA system
- Identifying the event during the flight test
- Creating a printable figure from selected parameters

## APPLICATION STRUCTURE

For flight data recorded by ACRA and from MUX- BUS MIL STD 1553B, the data files are in csv format. To load this type of data it was developed a dedicated class that use a database technology, creating a memory data table.

The class loads the data in system memory and can select, by the user option, the desired segment of data.

The selection is applicable for all parameters. The flight parameters section contains a friendly user interface that realizes multiple tasks.

For audio-video data provided by avionics system, also recorded by ACRA system, it was developed an direct show class. Because the video data is complex this class performs the following tasks:

- Programmatic creation of multifunctional multimedia graph to permit the rendering of audio-video information
- Sequential acquisition of video data in format bitmap
- Extract the VITC information from acquired bitmap
- Decode the extracted VITC information
- Reconstruction and rendering the original video information based on VITC decoded data
- Seek the recorded data on user selected time (relative or absolute)
- Seek the recorded data on user selected event (relative or absolute)

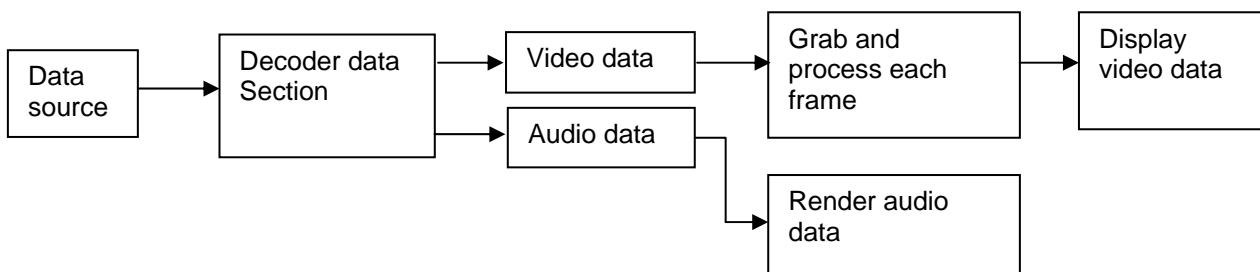

Fig. no. 1 Structure of direct show class

<sup>1</sup> PhD Eng

# NUMERICAL SIMULATION OF DFB-FL SENSORS FOR AERONAUTICAL APPLICATIONS

Ion LĂNCRĂNجان<sup>1</sup>, Sorin MICLOȘ<sup>2</sup>, Dan SAVASTRU<sup>2</sup>

<sup>1</sup> Advanced Study Center–National Institute of Aerospace Research "Elie Carafoli", 220 Iuliu Maniu Blvd, Bucharest, Romania, tel: +40214340078, fax: +40214340082, ilancranjan@incas.ro

<sup>2</sup> National Institute R&D of Optoelectronics-INOE 2000, 409 Atomistilor str., P.O.B. MG-5, Măgurele, Ilfov, Romania, tel:+40214575757, fax: +40214574522, miclos@inoe.inoe.ro; dsavas@inoe.inoe.ro

**Abstract.** *This paper presents the theoretical results obtained in analyzing the function and output noise of the distributed feedback fiber laser sensor. The main purpose of the performed theoretical analysis is to evaluate the magnitude of active FBG output noise. This evaluation is necessary for a proper design of active FBG sensor, especially regarding sensitivity and dynamic range. This paper presents the theoretical results obtained in analyzing the output noise generated by the active Fiber Bragg Grating (FBG) sensor. The main purpose of the performed theoretical analysis is to evaluate the magnitude of active FBG output noise. This evaluation is necessary for a proper design of active FBG sensor, especially regarding sensitivity and dynamic range. It is demonstrated that the main source of active FBG sensor output noise is constituted by the Amplified Spontaneous Emission (ASE) of the fiber amplifier. ASE is an intrinsic noise source of the active FBG sensor. ASE is basically due to fluorescent de-excitation of laser active ions of the fiber amplifier.*

**Keywords** -Active FBG sensor, ASE, fiber amplifier, sensor.

## 1. INTRODUCTION

This paper is a theoretical attempt relying on numerical simulations when necessary performed in order to get some insight on using a new and promising class of sensors for aeronautical applications, namely active Fiber Bragg Grating (FBG) known also as Distributed Feed Back Fiber Laser (DFB-FL).

Distributed feedback fiber lasers (DFB-FL) and distributed Bragg reflector fiber lasers (DBR-FL) possess certain unique properties that make them quite attractive for a number of different applications. They are inherently fiber compatible, and very simple passive thermal stabilization is sufficient to ensure the stability of the laser. A number of different active dopants, such as erbium, ytterbium, neodymium, and thulium, can be used in order to cover different windows of the optical spectrum. These features, combined with the ability to define the emitted wavelength precisely through the grating structure along with the narrow linewidth and low relative intensity noise (RIN), make DFB-FL and DBR-FL very advantageous for telecommunication applications [1]–[3]. In addition, a number of DFB fiber lasers can be configured in a parallel array to provide flexibility in pumping conditions and provide pump redundancy [2], [4]. Robust single polarization and narrow linewidth of DFB lasers are very desirable for sensor systems [5]–[7]. Alternatively, DFB lasers can be made to operate in stable dual polarization so that simultaneous measurements can be carried out [8]–[10]. In addition to the sensing and telecom applications, DFB fiber lasers suitable for high-power applications have been demonstrated [11].

An important feature of using DFB-Fiber Laser Sensors for various applications consists in the technology of analyzing the output. DFB-Fiber Laser Sensors are inherently fiber optic compatible, and very easy connected to other optoelectronic devices. One of the most important aspect to be considered in designing DFB-Fiber Laser Sensors is the technology used for converting the useful information/signal from the optic domain (the photons being the carriers) to the electronic domain (the electrons being the carriers).

The use of DFB-Fiber Laser as Sensors is based on observing the laser output variations versus the environment modifications. A "key" in designing properly DFB-Fiber Laser Sensors consists in a correct configuration of photo-detector circuit. DFB-Fiber Laser Sensors output variations can be caused by Er<sup>3+</sup> doped fiber optic amplifier (EDFA) and/or Bragg Grating parameters modification.

An important issue consists in designing the filters used to "cut off" noise of various types. It is important to understand what type of noise is filtered out, to understand its source. In this first part, some procedures considering the EDFA optoelectronic noise and used for designing such filters are presented.

## ANTITHERMAL SHIELD FOR ROCKETS WITH HEAT EVACUATION BY INFRARED RADIATION REFLECTION

Ioan RUSU

Electrica Serv, SISE Muntenia Nord, Str. Gh. Doja, nr. 37, bl. 45F1, ap.4  
Ploiesti, 100151, Romania, ioandanrusu@yahoo.com

**Abstract.** At high speed, the friction of air mass with the rocket surface produce local heating more than 1000 °C. For heat protection of rocket, on their outside surface are install antithermal shields.

Studing Coanda effect, respectively, the fluid flow on solids surface, the author Ioan Rusu discover by simply researches that the Coanda effect could be expanded also for the fluid flow on discontinuous solids, respectively, on solids with orifices. This phenomenon was named by the author, the expanded Coanda effect.

Start with this discovery, the author Ioan Rusu invent an antithermal shield, registered at Romanian Patent Office, OSIM, deposit F 2010 0153 This antithermal shield:

- is built as a covering rocket sheet with many orifices install with a minimum space from the rocket body
- take over the heat fluid generate by the frontal part of rocket and avoid the direct contact of heat fluid with the body of the rocket
- assure the evacuation of infrared radiation, generate by the heat fluid who flow on shield by expanded Coanda effect by reflection from rocket body surface

### INTRODUCTION

The fluid flow, liquids and gases, on solids, pursue the solids surface. This phenomenon was discovered by Henry Coanda and was named the Coanda effect (Figure 1).



Figure 1

By simply researches, the author Ioan Rusu discover that the Coanda effect could be expanded also for fluid flow on discontinuous solids. Practically, was demonstrate that on a solid surface with many orifices and at a special angle and for minimum speed of a fluid, on the surface of solid, the fluid follows the apparent surface of solid as a continuous sheet ( Figure 2, 3 and 4 ).



Figure 2



# REGARDING THE EVALUATION OF THE SOLID ROCKET PROPELLANT RESPONSE FUNCTION TO PRESSURE COUPLING

Doru SAFTA, Titică VASILE, Ioan ION  
Military Technical Academy in Bucharest, Romania, doru.safta@yahoo.com

**Abstract.** *High frequency combustion instabilities imply a major risk for the solid rocket motor stable working and they are directly linked to the propellant response to chamber pressure coupling.*

*This article discusses a laboratory test method for the measurement and evaluation of the pressure coupled response for non-metalized propellants in a first stage. Experimental researches were done with an adequate setup, built and improved in our lab, able to evaluate the propellant response by the interpretation of the damping of pressure oscillations in terms of propellant response.*

*Our paper aims at defining a linearized one-dimensional flow study model of the solid propellant rocket motors disturbed functioning analysis. On the basis of the applied model we can assert that the real part of propellant response is a function of the oscillations damping, acoustic energy in the motor chamber and various losses in the burning chamber. The imaginary part of propellant response mainly depends on the normalized pulsation, on the burning chamber gas column and on the pressure oscillations frequency.*

*Our research purpose was evident to minimize the risk of the combustion instabilities effects on the rocket motors working, by experimental investigations using jet modulating techniques and sustained by an interesting study model based on the perturbation method.*

## 1. INTRODUCTION

Combustion instability is a major concern in all propulsion and power generation systems. It is characterized by vibrations within the combustion chamber, generally measured as an oscillating pressure.

The pressure coupled response is the often referred parameter to describe combustion instability characteristics of a propellant.

It can be used to compare propellants destined for the same application and also the propellant response function can be used by motor stability prediction programs to compare the net driving by propellant combustion in a rocket motor.

An investigation of combustion instability in solid rocket motors was done in our labs considering the association of two principals: the disturbing of a subscale test motor by intermittent modulating of its nozzle throat, and the interpretation of the induced pressure oscillations damping in terms of propellant response.

It's about an interdisciplinary research study in order to realize a better modeling of the rocket motors perturbed working at high frequencies.

The high frequency pressure oscillations including their alternative components provide the main information to evaluate the propellant response.

Our theoretical researches were focused to define an adequate study model for the solid rocket motors disturbed working, mainly analyzing the propellant response to the pressure coupling and the time evolution of the pressure for various propellants.

We elaborated a complex program to simulate the motor disturbed working, which operates with a large termogasdynamical and engine construction data basis.

## 2. EXPERIMENTAL SETUP

Experimental researches were done with an adequate experimental setup, built in our lab on the basis of the nozzle throat modulating device developed by ONERA researchers [2, 3, 5], able to evaluate the propellant response by the interpretation of the damping of pressure oscillations in terms of propellant response.

The perturbed working simulation device, in the frame of jet intermittent modulating techniques, offers many investigation opportunities [3 - 6].

It is equipped with a special “teeth wheel” with 3 modulating teeth on a small wheel sector which spins at a given speed (depending on the studied range of frequencies) in a cross – section near the nozzle throat.

This autonomic setup measures by a dynamic quartz piezoelectric sensor the chamber pressure and records this data, for various grain shapes, and has multiple analyzing possibilities depending on time and frequency, Fig.1.

# Design of a Compact Six-Component Force and Moment Sensor for Aerodynamic Testing

Marin SANDU, Adriana SANDU, Georgeta IONAȘCU

“POLITEHNICA” University of Bucharest, Splaiul Independenței 313, 060042, Bucharest, Romania  
marin\_sandu@yahoo.com

**Abstract.** *The measurement of steady and fluctuating forces acting on a body in a flow is one of the main tasks in wind-tunnel experiments. Usually, a multi-component strain gauge force and moment sensor (also known as balance) is used to generate signals which are processed by means of an adequate instrumentation.*

*To design a wind-tunnel balance, the specifications of the load ranges and the available space (for the placement of the balance inside of the model or outside of the model) are required. The main challenge is to conceive the elastic element of the sensor as a monolithic part with relative simple geometry and to identify the adequate placement of strain gauges to maximize the measuring sensitivities and to diminish the inter-influence of the components.*

*This paper describes the design of a six-component force/moment sensor which is compact, has high measuring sensitivities, and can be used either as internal or as external balance in the aerodynamic testing.*

**Key Words:** *six-component sensor, wind-tunnel balance, design procedure*

## 1. INTRODUCTION

The force and moment strain gauge transducers have important applications in Aeromechanics, Robotics, Automatic Control and Monitoring Systems, Biomechanics.

Since the force and moment are vectorial physical quantities, their magnitudes and directions are used to define them. As is well known, a mechanical load can be divided into six components: three force components and three moment components. Consequently, to define completely the load, it is necessary to know the values of all six components.

A multi-component force/moment sensor is a device that enables forces and moments to be measured simultaneously. If they are placed inside of the model they are referred to as internal balances and if they are located outside of the model or the wind tunnel, they are referred to as external balances. There is limited space inside of the model itself, so internal balances have to be relatively small in comparison to external balances.

There are two main types of internal balances. The monolithic type, in which the balance body consists of a single piece, properly designed such that certain areas are primarily stressed by the applied loads.

The other internal balance type uses six small transducers which are oriented with their sensing axes in the direction of the applied loads. Such a balance is combined into a solid structure. A balance measures the total load acting on the model and therefore is placed at the center of gravity of the model.

The six different components of aerodynamic loads (three forces in the directions of the coordinate axes and the moments around these axes themselves), are measured in a certain coordinate system which can be either fixed to the model or to the wind tunnel.

The basic metrological features of multi-component strain gauge sensors are determined to a great extent by the shapes and sizes of elastic elements on which the strain gauges are bonded [1]-[8]. Due to the fact that the development of a strain gauge sensor is not a standard procedure, the designer's experience and intuition are very important.

The geometry of the elastic element of the sensor must comply with several metrological requirements concerning parameters as: nominal loads, allowed overload, measuring sensitivities, rigidities, linearity, hysteretic effects, interaction between the measured components, fatigue life, eigenfrequencies.

## 2. DESIGN DATA AND GEOMETRY OF THE ELASTIC ELEMENT

The components which act on the model and are required to be measured are the following: axial force  $F_{xm}$ , side force  $F_{ym}$ , normal force  $F_{zm}$ , rolling moment  $M_{xm}$ , pitching moment  $M_{ym}$ , yawing moment  $M_{zm}$ .

## Wind tunnel testing of the IAR 99 ȘOIM aircraft equipped with means for discovery and control of weather risk phenomena

Pătru SPĂȚARU\*, Florin MUNTEANU\*\*, Niculae MARIN\*\*

\*INCAS – National Institute for Aerospace Research “Elie Carafoli”, Bdul Iuliu Maniu 220, Bucharest 061136, Romania, pspataru@incas.ro

\*\*Aerospace Consulting, Bdul Iuliu Maniu 220, Bucharest 061136, Romania  
munteanu@incas.ro, marin@incas.ro

**Abstract.** This paper presents wind tunnel tests on an IAR 99 SOIM model equipped with means for discovery and control of weather risk phenomena. In order to obtain the aerodynamic characteristics of the new configuration of the IAR 99 SOIM necessary for its validation, a test program has been conducted in the transonic wind tunnel with a 1:14 scale model of the respective configuration. Reactive unguided projectile launchers, gas generators and containers for other equipment needed to detect and combat extreme weather were attached on the 1:14 scale IAR 99 SOIM model.

**Key Words:** COMAEROPREC, wind tunnel

### AIRBORNE COMPLEX PRESENTATION

As part of the realization of an airborne complex capable of a combined action on extreme weather events, wind tunnel experiments on the IAR 99 SOIM scale model equipped with means for discovery and combat of such phenomena were considered necessary.

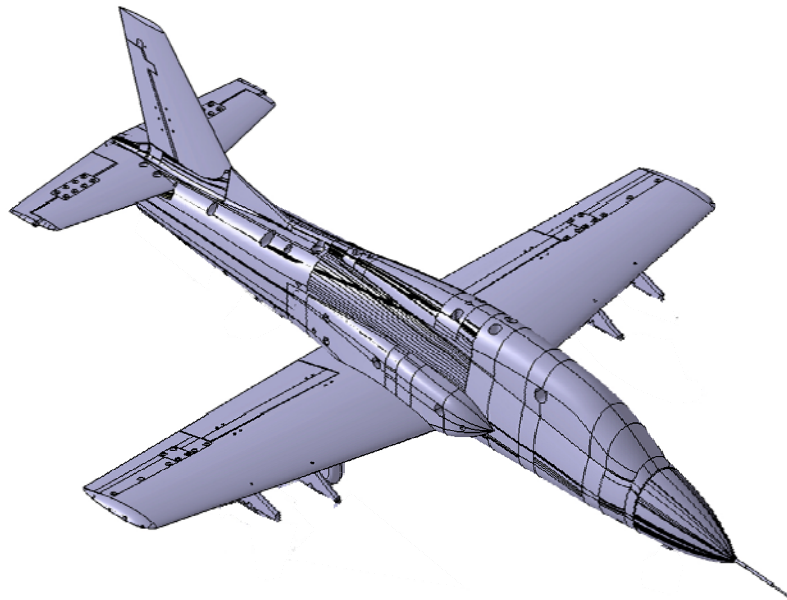

The IAR 99 SOIM scale model used for the experiments has been built based on the standard drawings and catalogs of IAR 99 and has a modular design.

The most important module is the center fuselage, to which almost all other modules are attached (forward fuselage, inlet plugs, rear fuselage and semi-wings) and which contains the strain gauge balance.

Experiments took place in the trisonic wind tunnel on the 1:14 scale model of the IAR-99 SOIM, equipped with the TASK 2.0 MK XXVI A six-component internal strain gauges balance of the mobile frame type, with a diameter of  $2\text{in} = 50.8\text{mm}$  and a length of  $8.9\text{in} \approx 226\text{mm}$ .

At the chosen scale, the reference geometric values of model will be:

- Wing surface area in horizontal projection  $S_m = 18,71/196 = 0,095459\text{m}^2$ ;
- Wing span theoretical in horizontal projection  $b_m = 9,85/14 = 0,703571\text{m}$ ;
- Mean aerodynamic chord, wing horizontal projection  $CMA_m = 0,140207\text{m}$ .

Model details are given in [3].

# EXPERIMENTAL RESEARCH METHODOLOGY APPLIED TO WIND TURBINE AERODYNAMIC BY MEANS OF STEREO PIV

Corneliu-Ioan STOICA, Radu BOGĂȚEANU  
INCAS - National Institute for Aerospace Research "Elie Carafoli",  
Bdul Iuliu Maniu 220, Bucharest 061126, Romania  
wwwcornel@yahoo.com, unquradu@gmail.com

**Abstract.** *This paper presents the work done at Delft University of Technology about the development of an experimental research methodology applied to wind turbine aerodynamics. An experimental campaign has been performed on a horizontal axis wind turbine model by means of Stereoscopic Particle Image Velocimetry (Stereo PIV). For its capability of providing a visualization of the three-dimensional structure of flows lends itself very well to the basic research requested by a not full knowledge of some physic phenomena. Besides a physic research tool the technique enables to obtain quantitative information of the flow details, allowing validation, and therefore development, of numerical models used in the analysis and design phase. Its characteristics of being highly not intrusive and capable of measuring simultaneously a wide region of space make it superior to other one-point measurement techniques. Rotational effects or near wake behaviour, if not new and faced also in propeller or helicopter fields, assume however different features and relevance. In order to achieve this deeper understanding of the physics an extensive experimental activity is fundamental. Experiments serve as basis for the formulation and as means of validation of new or modified models.*

## INTRODUCTION

In the field of wind energy there is a need to resume the basic research related to the aerodynamic profiles and in particular the aerodynamic profiles of wind rotors.

This need has two main causes, namely, from the point of view of the development process related to the optimization of the current configuration or research of new solutions and technologies that require a good knowledge of the physical phenomena involved. The second point of view is the current design process and its need to make effective use of certification tools to improve reliability and capability of current models.

## THE METHOD

This year we attended a doctoral internship training at the Faculty of Aerospace Engineering, the Wind Energy Department within the Tehnological University of Delft.

In the first stage were carried out a serie of experiments investigating the aerodynamic phenomena using Stereo PIV techniques (Stereoscopic Particle Image Velocimetry).

This recently developed technique, due to specific properties, is ideal for this kind of research. Its three-dimensional visualization capability of the flow structures are very well suited to the basic research of some natural phenomena still poorly investigated.

Besides the possibility of investigating physical phenomena this technique allows to obtain quantitative information on the details of the flow, and then to validate the mathematical models used in the analysis and design phases.

Being an almost non-intrusive technique and giving the possibility to measure simultaneously a large region from the spatial point of view, makes it a superior measuring technique.

Besides the qualitative information of flowing fields, can be analysed the separation points or current vortexes.

Despite of its complexity and high technological level of components used, the main idea of PIV measuring technique is simple:

- Small particles are introduced in flowing field and illuminated by a light plane.
- A series of images of particles are stored at a certain period of time
- The particle displacements are calculated by comparison of images
- Based on these calculated displacements and separation time, the flowing speed is calculated using the derivation method.

The PIV measuring system is generally made of four subsystems: the seeding system, illumination system, acquisition system and the data processing unit.

The quality of measuring depends strictly on adjustments made before and after the experiment of each component.

## **SECTION 7. Management in aerospace activities**



## Data Mining Techniques Used in Aeronautics Industry

Maria ANDRONIE<sup>1</sup>, Mihai ANDRONIE<sup>2</sup>  
Spiru Haret University, Bucharest, Romania  
andronie\_maria@hotmail.com, mihai\_a380@yahoo.com

**Abstract.** As the computer technology started to be used in almost all the fields of human activity huge quantities of data began to gather. In order to extract knowledge, data mining techniques and methods became more and more necessary, being used from company management to production and quality control, this trend affecting also the companies activating in aeronautics industry.

The most common types of data generated in the aeronautics are similar to those from other industries, being stored in data bases and data warehouses.

In the aeronautics industry there are also specific types of data like streams or time series that are not so common in other domains.

This paper presents an analysis of the most important data mining tasks and their possible applications in aeronautics.

The most common data mining tasks are clustering, association, classification, regression, forecast, sequence analysis and outlier analysis, but there are also others that can be successfully used in this field.

For an aeronautics company that intends to use data mining techniques to optimize its activity there are available a number of commercial tools on the market, each having its advantages and disadvantages.

**Key words:** data mining, aeronautics, production control in aeronautics.

### INTRODUCTION

Computer systems have become part of most industries in the last years, including aerospace, a domain that is highly computerized in most of its aspects.

This phenomenon had positive effects changing the employee's work from manager to ordinary worker.

Now almost all the technological processes are computer driven and generate data that is stored in databases and data warehouses. There are also very large quantities of data in the form of streams generated all the time and that are too large to be stored, but can be analyzed to extract useful knowledge.

By using knowledge extracted from the existing data that is generated in aeronautics enterprises, there is the possibility to improve the technological processes, improving their efficiency. In this way the managers can take better decisions.

A data mining system contains a number of techniques and methods used to make an advanced data analysis and can be used in almost all fields of human activity where there are large data bases or data warehouses [3].

Data mining techniques can be applied for providing better security in airports, for diagnosing technical problems at airplanes, for the management of aeronautics companies and so on.

### DATA TYPES THAT CONTAIN USEFUL KNOWLEDGE

Useful knowledge can be extracted from a multitude of data types in general from all the human activities and in special from the aerospace industry, where there are also some special features.

As in other fields of the industry, there are usually the same types of data that is generated and stored, so it is important to have a suitable data mining system. Following will be enumerated the main types of data that a data mining system can handle, emphasizing those types that are more important [3]:

- Data bases (usually relational);
- Data warehouses (data gathered and integrated from multiple sources);
- Stream of data;
- Time series and sequences;
- Graph and social network data.

---

<sup>1</sup> Conf. univ.dr.

<sup>2</sup> Asist. Univ. drd.

# New Applications of Enterprise Resource Planning in the Aeronautics Industry

Maria ANDRONIE<sup>1</sup>, Mihai ANDRONIE<sup>2</sup>  
Spiru Haret University, Bucharest, Romania  
andronie\_maria@hotmail.com, mihai\_a380@yahoo.com

**Abstract.** *In the past years Enterprise Resource Planning (ERP) developed in many fields of the industry to help companies with the management of the internal processes. ERP, as a complete software solution, can assist most of the activities in an aeronautics company, from manufacturing to human resources and financials.*

*The main advantages of using ERP are reflected in better quality products, better customer service, etc. However it is not enough for a company to be successful on the market. New improvements to ERP like data mining and connection to the internet are improving the case, bringing even more advantages to those who use them.*

**Key words:** *data mining, enterprise resource planning, information technology.*

## INTRODUCTION

*Enterprise resource planning or ERP can be defined as a "company-wide computer software system used to manage and coordinate all the resources, information, and functions of a business from shared data sources" [10].*

*Enterprise resource planning can be used in various fields of activity, in all kinds of companies like those active in the aeronautics industry.*

*Usually ERP consists of different modules linked by a network and has a centralized database [10].*

*ERP has its origins in the industry beginning with the MRP (Material Resource Planning) used for the first time in the industry for production control.*

*From then things changed, the first ERP appearing in the '90s, besides production processes being able to cover more activities in a company like stocks, human resources, accounting and so on. In the last years new technologic advances made possible the integration into ERP of more advanced modules like data mining.*

*The development of the internet had also an important impact, allowing an easier information transfer between the stakeholders of a company.*

*By using ERP systems, companies in the aeronautics industry have a multitude of advantages some of the most important being the ability to tune production processes according to other variables, the possibility for managers to see the evolution of their company in real time, as things are happening and a more efficient working frame for the employees.*

## 1. STRUCTURE OF ERP IN INDUSTRY

*Enterprise Resource Planning is usually structured in a number of modules interconnected by a communication system that is usually a local area network [10].*

*While a complete ERP solution can cover most of the activities of an aeronautics company, having modules for different activities like human resources or production control, it is not always necessary for the company to buy all the modules from the same producer.*

*Every module can be implemented separately, the system being open. For example database technology can be integrated in an ERP system at an earlier stage and later can be added a data mining subsystem to analyze the data stored.*

*This modularity is good for companies because they can extend their ERP system according to their needs, without being necessary to buy a complete expensive solution from the beginning.*

*Companies can buy ERP subsystems from different vendors or even build their own modules according to their needs, the only concern being the compatibility and communication between these modules.*

---

<sup>1</sup> Conf. univ.dr.

<sup>2</sup> Asist. Univ. drd.



# MANAGEMENT BASED ON COSTS IN THE AERONAUTIC INDUSTRY AND RESEARCH IN ROMANIA

Aurelian Virgil BĂLUȚĂ  
Spiru Haret University, Bucharest, Romania  
aurelian.baluta@yahoo.com

**Abstract.** *The article starts from the premise that many decisions of the management based themselves on costs. In the article, there is a review of the methods of adequate costs organization for aeronautics industry and research. They are submitted to the conditions of aeronautics industry. Such methods are: the method on commands, the method on phases, the direct-costing method, the method of fixed costs rational imputation, the ABC method, the target-costing method, the tariff-hour-car method. There are assessed the specific approaches of project calculation. For each method, there are presented the advantages and disadvantages specific for aeronautics industry and research.*

**Key words:** *costs, management, aeronautics industry, aeronautics research, methods of the costs information system.*

## INTRODUCTION

Establishing a system to measure performance is a component part of the management of any organisation. By such a system there are made available instruments and means required by the organisation to gather information, to define objectives, to analyse and check the required evolutions to follow performances included in the budget. One of the methods widely used under the conditions of activity restructuring, as it is the case of the industry and the aeronautic research, is the costs-based management.

Generally, the studies regarding the costs-based management remain in the phase of general description, namely the principles formulation.

By this communication I have in view the description of elements which are specific to the industry and the research from the aeronautic industry.

I start from the general rules of the costs-based management and from the specific features of the industry and aeronautic research under the conditions of an average sized country in progress of consolidating the Euro-Atlantic structures.

From this perspective, communication falls into the category of study of votive methods of the enterprise management with specialised profile that is the costs-based management.

## 1. UTILITY OF COSTS-BASED MANAGEMENT IN THE AERONAUTIC INDUSTRY AND RESEARCH

The costs-based management enables the planned decisions spread enhancement and the diminution of the unplanned ones spread.

The aeronautic industry and research are anyway activities implying the occurrence of the unpredictable in making decisions.

Predominantly in countries with major development offsets and with no leading position on the international aeronautic market as it is Romania, the potential in the aeronautic industry and research can be in the first instance capitalized within remittent orders involving a large spread of the unpredictable for management.

Through the costs-based management there takes place a limitation of the impact of these decisions categories. It is easier to establish clear procedures and to achieve a standardisation of the decision making pattern when cost is taken as reference item. Many activities relating to the unique projects to which the aeronautic industry and research must face can be modelled so as to appear as repetitive situations or routine works.

Cost is a mandatory element of any project and linked to it there can be defined sets of rules to follow in different types or orders received by the organisations in the aeronautic industry and research, even if they suppose the settlement of technological complex issues or regarding correlation of resources allotment.

The complexity and the degree of novelty of issues in the aeronautic industry and research suppose more and more the passage from decisions involving the best solutions or maximum

# Overview on educational FP7 Project - REStARTS - Raising European Students Awareness in Aeronautical Research Through School-Labs

Claudia DOBRE

INCAS – National Institute for Aerospace Research "Elie Carafoli"  
Bdul Iuliu Maniu 220, Bucharest 061136, Romania  
cdobre@incas.ro

**Abstract.** *Developments in Science and Technology have always been an essential part of the progress of all societies. In the past decades, the attraction towards Science and Technology has significantly decreased, although our society is more dependent on Science and technology than ever.*

*In order to improve the current situation, specific actions are needed at all levels in the educational process, starting from early stages up to universities.*

*Few major European aeronautical institutes felt the need to do something to put an end to this drop of interest among young people.*

*The partners of REStARTS are aeronautical research institutes in Europe (VKI in Belgium, CIRA in Italy, DLR in Germany and INCAS in Romania) which have considerable experience in this field. Additionally, an educational partner, the School of Education University of Leicester in UK, will supervise the accessibility and the impact of the resulting product toward teachers and students.*

*The activities are focused on experiments in class and dedicated labs and visits at the research institutes, where young students can benefit best from the research infrastructure and knowledge accumulated in complex research projects.*

*The long-term objective of the present project is to establish a European platform, with a pilot experience, that will result in teaching material on aeronautics.*

**Key Words:** *aeronautical educational project, link between research organizations and academia, teaching materials on aeronautics, experiments in class, school labs.*

## 1. INTRODUCTION - BACKGROUND

Developments in Science and Technology have always been an essential part of the progress of all societies.

In the past decades, the attraction towards Science and Technology has significantly decreased, although our society is more dependent on Science and technology than ever.

A growing gap has gradually built between scientists and the public and this has resulted in an increasing drop of interest of people, particularly youngsters, towards science and technology.

A very limited number of young boys and girls are attracted towards engineering activities, including aeronautics.

## 2. CONCEPT AND OBJECTIVES OF REStARTS

In order to improve the current situation, specific actions are needed at all levels in the educational process, starting from early stages up to universities. Joint actions at EU level are necessary in the global context of integration and harmonization of resources.

Few major European aeronautical institutes felt the need to do something to put an end to this drop of interest among young people.

The partners of REStARTS are research and training establishments in Aerospace (VKI in Belgium, CIRA in Italy, DLR in Germany and INCAS in Romania) which have considerable experience in aerodynamics and related areas.

Additionally, to these specialists in aeronautics, an educational partner, the School of Education University of Leicester in United Kingdom, will supervise the accessibility and the impact of the resulting product toward teachers and students.

The concept of the REStARTS project is to establish a well co-ordinated link and work plan among the research organizations in aeronautical sciences and academia for sharing the know-how, special/ dedicated research infrastructure, and the latest research results in order to improve the educational process of a new generation of engineers for the European aeronautics industry.

The objective is to make a significant impact on the educational process and to raise the public awareness from a very early stage to the technological challenges in aeronautics.

The activities are focused on dedicated labs, where young students can benefit best from the research infrastructure and knowledge accumulated in complex research projects.

# ADVANCED AEROSPACE MANAGEMENT OF INTEGRATED EDUCATION AND TRAINING TOWARDS COMPREHENSIVE SECURITY

Miroslav KELEMEN\*, Pavel NEČAS\*, Peter TEREM\*\*

\*Armed Forces Academy of General Milan Rastislav Štefánik, Demänová 393,  
031 06 Liptovský Mikuláš, Slovak Republic

\*\*Matej Bel University, Kuzmányho 1, 974 01 Banská Bystrica, Slovak Republic  
miroslav.kelemen@aos.sk, pavel.necas@aos.sk, peter.terem@umb.sk

**Abstract.** *The aviatic integrated education and training based on the progressive technologies towards comprehensive security will be necessary for the future specialized preparation and training of the personnel in civil and military aerospace management and aviation, especially for expeditionary missions. The integrated pilot flight preparation and training based on the modern methodology of situational control would be used for improving our general system of present preparation and training, within the framework of the Armed Forces of the Slovak Republic.*

**Key Words:** *Aerospace Management; Flight Preparation; Education and Training; Situational Control; Comprehensive Security; Sophisticated Techniques and Technologies.*

## 1. INTRODUCTION

The high quality and professionally advanced personnel is the highest value for each flight operator. That is why the involved controllers, as an operator, pay attention to the development of education and training system and change it into high quality, effective and safe task fulfilment.

The specific mission and variety of air activities influence the prior trend, content and forms of air personnel preparation.

At the same time, we manage to control and secure the complex preparation only through the close co-operation of available aviation educational institutions and training centres in compliance with aviatic educational sources.

## 2. COMPREHENSIVE SECURITY BASED APPROACH

The national system of education and professional development of personnel in the Armed Forces of the Slovak Republic (AF SR) is built in accordance with the strategic “Long term plan of structure and development of personnel in the Armed Forces of the Slovak Republic – Model 2010” [3], approved by the National Council of the Slovak Republic.

The main goal of the national education system and professional development of the Armed Forces of the Slovak Republic, controlled by the Ministry of Defence of the Slovak Republic (MOD SR) and General Staff AF SR, is to provide the complex professional preparation of personnel on the base of building and development of their competencies to fulfil the tasks of the armed forces, as guaranty of national safety, in accordance with the Constitution and the Slovak Republic laws, as well as with international state commitments.

Under the term of professional soldier competencies, we understand his psycho-physiological and social-psychological qualities and activities in accordance with his professional qualification to function.

Building and development of personnel competencies of professional soldiers significantly influences building and development of required abilities of armed forces by themselves, which we perceive as a total, complicated system.

The Air Force of the Armed Forces of the SR, in accordance with the tasks and international commitments of the Slovak Republic, need to prepare, within the aviatic education, a military professional who should fulfil the following requirements:

- To be motivated, educated, theoretically and practically prepared to function in a domestic and international environment, with skills in informatics and simulation technologies;
- To be technically skilled, psychically strong, physically able, capable to take independent decisions and practise (or to be „a team player“ in a flight crew and military unit), critical to himself and the environment,
- To be a personality with the system approach and viewpoint concerning events and processes;

## Some Aspects Regarding “Sense and Avoid” Requirements for UAV Integration In the National Air Space

Adrian MURARU, Gheorghe MATIȘ

Air Force Academy "Henri Coandă", Brașov, Romania, muraruady@gmail.com

**Abstract.** *The purpose of this article is to show the importance of mission planning in a fully automatic flight and the critical role of implementing Sense & Avoid (S&A) procedures at different categories of UAVs. Modern operation of UAVs implies the capability to handle separation provision and collision avoidance in a way similar to the manned aircrafts. The main contributions are: the analysis of the importance of organizing a special course dedicated to the technical knowledge of the procedures for mission planning and utilization of UAVs; a critical analysis of the possibilities of integration S&A procedures for small UAVs and the perspective of obtaining low-cost solution, especially for emerging countries.*

**Keywords:** UAV - Unmanned Aerial Vehicle, UAS - Unmanned Aircraft System, S&A – Sense and Avoid.

### 1. INTRODUCTION

An unmanned aerial vehicle is an aircraft that flies without a human pilot on board. The responsibility for the control of this type of aircraft falls upon on either a human operator on the ground or fly's autonomously based on pre-programmed flight plans using more complex dynamic automation systems.

At first, UAVs were simply target drones for military aircrafts or artillery. Nowadays, the technology has advanced to the point where human pilots could be replaced by the sense and avoid system.

The problem of sense & avoid can be divided in two separate functions: the sense function and the avoid function, with each one having several sub-functions (either allocated to a technical system or the human operator).

The development of a Sense & Avoid System raises a couple of questions, each of which requires its own dedicated experimental design.

According to a FAA (Federal Aviation Administration) definition in 2009 “Sense and Avoid (SAA) is the capability of an UAV to remain well clear and avoid collisions with other airborne traffic”.

The task of identifying possible conflicts and avoiding them is still in the responsibility of the human operator. Studies show, that even for an experienced pilot, it takes already a few seconds to identify possible conflicts after detecting an intruder.

Future unmanned systems in the military will be highly heterogeneous in nature, with vehicles from multiple domains: aerial, underwater, and land, working in collaborative teams to complete a variety of missions.

The complexity of supervising these teams will be enormous and will rely on human creativity, judgment, and experience.

Therefore, the design and development of mission planning and monitoring technologies must be rooted in a deep understanding of the human operator's role as mission manager, and must effectively address the reasoning skills and limitations of both the human and autonomous intelligent system.

### 2. CURRENT SITUATION OVERVIEW

The sense & avoid capability is considered to be essential for the operation of UAV in non segregated airspaces.

The primary distinction of Unmanned Aircraft Systems (UAS) from manned aircraft, the removal of the pilot from the cockpit, raises the issue of how collisions are to be avoided.

Many research initiatives are exploring concepts and technologies for the “Sense & Avoid” function (S&A), including adapting some already used onboard manned aircraft.

The current procedure for a UAS to operate in national airspace (NAS) requires a Certificate of Authorization (COA) to be applied for through the FAA for every mission.

## Aircraft "Advanced Jet Trainer/ Light Fighter Jet"

Sorin Ștefan RADNEF\*, Victor EMANOIL\*\*

\*INCAS - National Institute for Aerospace Research "Elie Carafoli", Bucharest, Romania,  
sradnef@incas.ro

\*\*Aerospace Consulting Bucharest, Romania

**Abstract.** *The paper deals with the problems encountered by the management of the Development - Modernization, DM, of an aircraft which is in current manufacturing. There are emphasised some steering lines to be followed when approaching such an objective.*

### INTRODUCTION

An advanced jet trainer aircraft meeting the requirements for 2015 may be an objective related to the development/ modernization of the common Romanian jet trainer IAR-99.

That is why a study of such an aircraft is done from the view point of the management in aerospace activities.

The paper is focused mainly on general constraints of such a development and modernization coming from the known history of design, research, manufacture, regular maintenance and operation/ tests of the aircraft IAR-99, alongside with those arising from management requirements and current - immediate objectives. On the other hand we take into account the design features emphasized by the Joint Strike Fighter new class of the U S F, considering F 35-A, F 35 - B - STOL, F 35 - C - CTOL (CV), EA 35 B.

### GENERAL REQUIREMENTS FOR DM

These requirements concern mainly the following questions:

1. Eliminating the unsuitable phenomena for a normal flight
  - a. stick felt vibrations
  - b. unstable aiming at the target
  - c. poor air intake during cannon firing
  - d. too small flight range
  - e. too low flight max. speed
2. Eliminating the design "clumsiness" such as:
  - a. landing gear positioning between beams
  - b. motorization under 0.4 of the aircraft weight
  - c. tail group placed in the area of influence of the reactive jet
  - d. redesigning the wing-fuselage junction
  - e. redesigning the wing to fuselage connections
3. Gradual and phased changing of technologies and manufacturing flow.
4. Maintaining the resistance structure at least in the first stage of development.
5. Establishing the requirements of the general aerodynamics (overall aerodynamic and control torsor) and of the propulsion system complying with the general requirements of the FQ and aircraft performance according to the main flight missions.
6. AO and AV re-evaluation: shape, surface, position regarding the management conditions control and efficiency improvement.
7. Generalizing the required configuration for two pilot posts.
8. Evolution towards a UAV testing prototype.

### REQUIREMENTS REGARDING THE DM MANAGEMENT

Considering that we currently have in production a similar advanced trainer aircraft, we derive the following essential requirements:

1. Identification of mission specific requirements considering the development conditions.
2. Each DM step should "solve" at least one of the functional deficiencies that were found in operation and that required human and financial efforts.

# From Collaborative Network Organization Towards Future Internet Enterprise Systems in Aeronautics Industry

Aurelian Mihai STĂNESCU, Ioan DUMITRACHE, Mihnea Alexandru MOISESCU,  
Ioan Ștefan SACALA, Irina Gabriela LOLU

University “Politehnica” of Bucharest, Faculty of Automatic Control and Computers  
Bdul Splaiul Independentei 313, Bucharest 060042, Romania  
ams@cpru.pub.ro, idumitrache@ics.pub.ro, mamihnea@gmail.com, sacalaioan@yahoo.com,  
lolu\_irina@yahoo.com

**Abstract.** Due to the globalization meta-phenomenon, as well as high innovation pressure in the ICT, both the academic research and companies R&D departments developed new concepts like Extended Enterprise, Virtual Enterprise and Virtual Organization, Network Enterprise. The recent successfully ended FP7-IST projects proposed the new scientific discipline so-called Collaborative Network Organization (CNO). The paper intends to prove the critical importance of the Future Internet Enterprise Systems, as it is the case in the aerospace industry. The development of new concepts in the area of enterprise collaboration like: CNO and Digital Business Ecosystem, the large scale utilization of the Service Oriented Architecture using the new infrastructure provided by Cloud Computing technologies and the ongoing demand for communication and collaboration is stressing to the limits the current internet technologies and infrastructure. In this context the development of new Internet related concepts and technologies oriented towards providing positive benefits for individuals, society, economy, culture and environment has been included in a broad concept of Future Internet Systems. The development of Future Internet Enterprise Systems has been oriented towards enabling enterprises and SMEs access to the full potential of Future Internet technologies through ICT.

**Key Words:** Network Organization, Future Internet Enterprise Systems.

## 1. INTRODUCTION

According to Kuhn’s famous book [7], the source of last severe decades of troubles in post-second world wide war civilization might be identified as “SCIENTIFIC CRISIS”. This crisis appeared when “even best professional practices persistently prove inadequate for solving some intrinsically important problems”.

Kuhn shows that “the way out of a scientific crisis is “SCIENTIFIC REVOLUTION” as well as for developing new methods and tools”.

The Concurrent Enterprise (CE) has become a grand challenge for engineering since 1982 (D.A.R.P.A.-US agency initiative). Together with Total Quality Management (TQM), Business Process Reengineering (BPR), Change Management of Organizations Modelling Framework (CM/OMF), the CE has promoted the cross-departmental new ways of co-work among different specialized teams / sub teams.

Latter on the research topics encompassed intra / inter organizations information exchange like EXPRESS / STEP for complex CAD files electronic exchange [7]. One could remember that the consortium AMICE [AMICE 1989] launched the research to exchange files to support “Business 2 Business” co work. It is interesting to mention that today research topics to solve the INTEROPERABILITY [11] have “roots” during “AMICE”-Esprit project.

The Research and Development roadmap (R&D / ICT) could be summarized as in Figure 1. The four basic paradigms shifts have been identified.

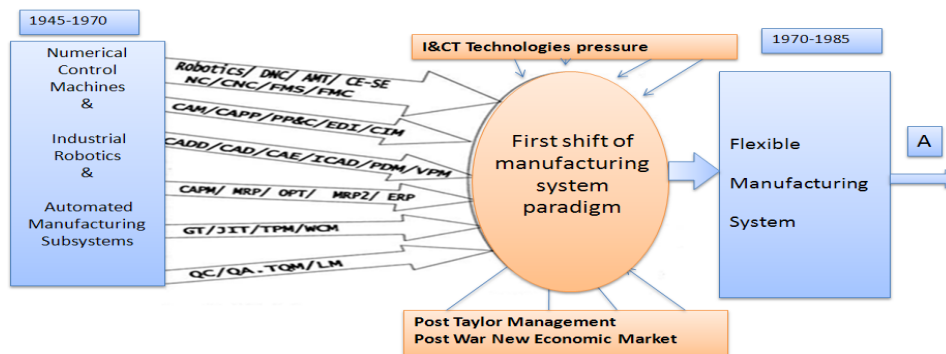

# INTEGRATING THE SAFETY DIMENSION IN MODERN AIR TRAFFIC MANAGEMENT

Virgil STANCIU, Irina Carmen ANDREI, Gabriela Liliana STROE  
“POLITEHNICA” University of Bucharest, Faculty of Aerospace Engineering, Department “*Elie Carafoli*” of Aerospace Sciences, Department “*Nicolae Tîpe*” of Avionics, Engineering and Management in Aeronautics, Str. Gh. Polizu 1, sector 1, Bucharest, 011061, Romania, v\_stanciu@aero.pub.ro

**Abstract.** *This paper presents a thorough investigation of the key-drivers for a successful management dedicated to the improvement of the air transport system safety, which today represents a worldwide concern. The workload profile for interested target categories of personnel (e.g. the pilots and air traffic AT controllers that are capacitated to take real-time decisions) are analyzed.*

*The purpose is to shape out the significant elements that can be used as markers & means to early detect and prevent any possible cause of failure and thus to enabling the desired safety levels and/ or to improve the safety of air transports.*

**Keywords:** *safety of aircraft transportation/ air transport system, air traffic AT, management, strategy, roles, responsibilities, workload profile, human factor.*

## 1. INTRODUCTION

### 1.1 JUSTIFICATION: WITHIN JURIDIC FRAME

Following the adherence to the EUROCONTROL Convention<sup>1</sup> in May 1996 and the adherence to the EUROCONTROL Convention<sup>2</sup> in June 1997, the adherence to NATO in 2002 and the prospective adherence to the European Union in 2007, Romania must satisfy the provisions of the European Community acquis.

Along the direction of harmonization and integration Romania has made significant steps, but there is still a long way to go ahead.

Taking full account of the ICAO<sup>3</sup>, the EATCHIP<sup>4</sup> and the CFMU<sup>5</sup> were introduced to combat the ATC<sup>6</sup> delays (which were due to the inability of the ATM network and airports capacity to cope with the increasingly demand). In 1992 work started on the formulation of an ATM concept for Europe covering a 2005-2015 time-frame, taking full account of the ICAO CNS/ATM global developments, encapsulating the principles of continuous gate-to-gate flight management, and within a harmonized implementation and transition strategy.

This was followed by the development of an ATM Strategy for the years 2000+, setting out the processes and measures by which the forecast demand in Europe could be met. Together, the Operational Concept Document and the ATM Strategy for 2000+ provide a comprehensive view of how ATM in Europe should develop into the early part of the 21st Century.

Nevertheless, the ATM Strategy can be adjusted properly in order to be able to prevent/ manage crisis situations (e.g. aircraft detoured, terrorist attacks, the occurrence of en-chained events that eventually may lead to an aviation catastrophe<sup>7</sup>).

## 2. GROUNDS FOR: AIR TRAFFIC MANAGEMENT STRATEGY

According to the Air Traffic Management ATM Strategy<sup>8</sup> that was developed by the EUROCONTROL in order to meet the needs of the users for the early part of the 21<sup>st</sup> century, there are two main directions: **short term action** and **the reform**. Both are described in terms of **specific objectives** for every mile stone.

<sup>1</sup> That refers to the cooperation for the safety of traffic flow and global agreement for route pricing.

<sup>2</sup> That refers to the working out of a local plan of actions in order to fulfil its obligations assumed.

<sup>3</sup> The International Civil Aviation Organization = ICAO (abbreviation).

<sup>4</sup> The European Air Traffic Control Harmonization and Integration Program = EATCHIP (abbreviation).

<sup>5</sup> The Central Flow Management Unit = CFMU (abbreviation).

<sup>6</sup> The Air Traffic Control = ATC (abbreviation).

<sup>7</sup> **Reminder:** the collision between a Russian air liner flying from Moscow to Spain and an UPS air-cargo flying from Germany to Austria; due to an erroneous interpretation of the Traffic Alert and Collision Avoidance System **TCAS** indications vs. the AT controller's demand (at the Sky Center, in Zurich) the trajectories of the two aircrafts crossed over Switzerland and eventually crashed in a terrible accident.

<sup>8</sup> This document became operational since 28 January 2000.

## **List of Authors**





**A**

- Maria ALEXANDRESCU INCAS - National Institute for Aerospace Research "Elie Carafoli",  
Bucharest, Romania  
e-mail: malex@incas.ro
- Nicușor ALEXANDRESCU INCAS - National Institute for Aerospace Research "Elie Carafoli",  
Bucharest, Romania
- Irina Carmen ANDREI "POLITEHNICA" University of Bucharest, Faculty of Aerospace  
Engineering, Department "Elie Carafoli" of Aerospace Sciences,  
Department "Nicolae Tîpei" of Avionics  
e-mail: icandrei28178@gmail.com
- Maria ANDRONIE Spiru Haret University, Bucharest, Romania  
e-mail: andronie\_maria@hotmail.com
- Mihai ANDRONIE Spiru Haret University, Bucharest, Romania  
e-mail: mihai\_a380@yahoo.com
- Viorel ANGHEL "POLITEHNICA" University of Bucharest, Department of Strength of  
Materials, Laboratory for integrity evaluation of composite structures  
e-mail: v\_m\_angel@yahoo.com
- Ștefan ANTOHE Department of Solid State Physics, University of Bucharest,  
Magurele-Ilfov, Romania  
e-mail: santohesolid.fizica.unibuc.ro
- Vlad Andrei ANTOHE Department of Solid State Physics, University of Bucharest,  
Magurele-Ilfov, Romania
- Dragoș Alexandru APOSTOL Department of Strength of Materials, "POLITEHNICA" University of  
Bucharest  
e-mail: apostolda@yahoo.com
- Nicolae APOSTOLESCU INCAS - National Institute for Aerospace Research "Elie Carafoli",  
Romania  
e-mail: apostol@incas.ro

**B**

- Agneta M. BALINT West University of Timisoara, Romania
- Ștefan BALINT West University of Timisoara, Romania  
e-mail: stefanbalint@gmail.com
- Alexandru Tristian BALMUȘ Aerostar SA Bacau, Romania  
e-mail: aerostar@aerostar.ro
- Aurelian Virgil BALUȚĂ Spiru Haret University, Bucharest, Romania  
e-mail: aurelian.baluta@yahoo.com
- Daniela BARAN INCAS - National Institute for Aerospace Research "Elie Carafoli",  
Romania  
e-mail: dbaran@incas.ro
- Corneliu BERBENTE "POLITEHNICA" University of Bucharest, Faculty of Aerospace  
Engineering  
e-mail: berbente@yahoo.com
- Sorin BERBENTE "POLITEHNICA" University of Bucharest, Faculty of Aerospace  
Engineering

Cristina BEȘLEAGĂ	Department of Solid State Physics, University of Bucharest, Magurele-Ilfov, Romania
Radu BÎSCĂ	INCAS - National Institute for Aerospace Research "Elie Carafoli", Romania e-mail: biscar@incas.ro
Mircea BOCIOAGĂ	MAGIC Engineering S.R.L., Brasov, Romania e-mail: mircea.bocioaga@magic-engineering.ro
Radu BOGĂȚEANU	INCAS - National Institute for Aerospace Research "Elie Carafoli", Romania e-mail: unquradu@gmail.com
Ștefan BOGOS	GECE Engineering Services s.r.l. Romania e-mail: stefanb@geci.ro
Henri-Claude BOISSON	Institute of Fluid Mechanics Toulouse, France
Dionezie BOJIN	"POLITEHNICA" University of Bucharest
Andreea BORÎTU	"POLITEHNICA" University of Bucharest, Department of Strength of Materials, Laboratory for integrity evaluation of composite structures
Mircea BOȘCOIANU	Air Force Academy "Henri Coanda" Brasov e-mail: prorector_cercetare@afahc.ro
Adina Otilia BOTEANU	Military Equipment and Technologies Research Agency, Romania e-mail: boteanuotilia@yahoo.com
Dan BRAȘOVEANU	CSC-Washington USA
Marius BREBENEL	"POLITEHNICA" University of Bucharest e-mail: mariusbreb@yahoo.com
Gigi-Daniel BUDARIU	Military Equipment and Technology Research Agency, Romania e-mail: gbudariu@acttm.ro
Valentin BUTOESCU	INCAS - National Institute for Aerospace Research "Elie Carafoli", Romania e-mail: vbutoesc@incas.ro, valentinbutoescu@yahoo.com

## C

Bogdan CALOIAN	Department of Strength of Materials, "POLITEHNICA" University of Bucharest e-mail: caloian.bogdan@yahoo.com
Adrian CARABINEANU	University of Bucharest e-mail: acarab@fmi.unibuc.ro
Vladimir CARDOȘ	"Gheorghe Mihoc-Caius Iacob" Institute of Mathematical Statistics and Applied Mathematics of Romanian Academy e-mail: v_cardos@yahoo.ca
Alexandru-Laurențiu CĂTĂNESCU	National Institute of Electrical Engineering Researches-Advanced Researches (INCDIE-CA), Dep. MNE, Romania
Mircea Dimitrie CAZACU	"POLITEHNICA" University of Bucharest, Hydraulics and hydraulic Machines Department e-mail: cazacumircea@yahoo.com

Zdeněk CHÁRA  
Institute of Hydrodynamics, Academy of Sciences of the Czech Republic  
e-mail: chara@ih.cas.cz

Adrian CHELARU  
"POLITEHNICA" University of Bucharest

Teodor-Viorel CHELARU  
"POLITEHNICA" University of Bucharest  
e-mail: teodor.chelaru@upb.ro

Constantin CIOLOFAN  
SC INAS SA Craiova, Romania  
e-mail: ciolofan@inas.ro

Marius Gabriel COJOCARU  
INCAS - National Institute for Aerospace Research "Elie Carafoli", Romania  
e-mail: marius.gabriel.cojocaru@gmail.com

Nicolae CONSTANTIN,  
"POLITEHNICA" University of Bucharest, Department of Strength of Materials, Laboratory for integrity evaluation of composite structures

Dan Mihai CONSTANTINESCU  
Department of Strength of Materials, "POLITEHNICA" University of Bucharest  
e-mail: dan.constantinescu@upb.ro, d\_constantinescu@yahoo.com

Andrei CRĂIFĂLEANU  
"POLITEHNICA" University of Bucharest  
e-mail: ycraif@yahoo.com

Ștefan Gicu CRUCEANU  
"Gheorghe Mihoc-Caius Iacob" Institute of Mathematical Statistics and Applied Mathematics of Romanian Academy  
e-mail: scruceanu@csm.ro

**D**

Sterian DĂNĂILĂ  
"POLITEHNICA" University of Bucharest, Faculty of Aerospace Engineering  
e-mail: sterian.danaila@upb.ro

Mirela DARAU  
West University of Timisoara, Romania

Alin George DIACONU  
"POLITEHNICA" University of Bucharest, Faculty of Aerospace Engineering  
e-mail: alin07\_a@yahoo.com

Sorin DIMITRIU  
"POLITEHNICA" University of Bucharest  
e-mail: sorindimitriu@yahoo.com

Ion DINCĂ  
Aerospace Consulting, Romania  
e-mail: dincaion@incas.ro

Sorin DINEA  
"POLITEHNICA" University of Bucharest, Faculty of Aerospace Engineering  
e-mail: sorin@aerodin.ro

Claudia DOBRE  
INCAS - National Institute for Aerospace Research "Elie Carafoli", Romania  
e-mail: cdobre@incas.ro

Bogdan DONCIU  
"POLITEHNICA" University of Bucharest, Romania

Alexandru DUMITRACHE  
"Gheorghe Mihoc-Caius Iacob" Institute of Mathematical Statistics and Applied Mathematics of Romanian Academy  
e-mail: alex\_dumitrache@yahoo.com

Ioan DUMITRACHE	"POLITEHNICA" University of Bucharest, Romania, Automatic Control and Applied Informatics Department e-mail: ioan.dumitrache@cncsis.ro
Liviu DUMITRACHE	ICECHIM - National Institute for Research & Development in Chemistry and Petrochemistry
Adrian DUMITRESCU	Aerostar SA Bacau, Romania
Horia DUMITRESCU	"Gheorghe Mihoc-Caius Iacob" Institute of Mathematical Statistics and Applied Mathematics of Romanian Academy e-mail: horiadumitrescu@yahoo.com
Eugen DUMITRU	Research and Flight Test Center, Romania e-mail: eugendumitru@ftc.ro
<b>E</b>	
Ioana Raluca EDU	University of Craiova, Faculty of Electrical Engineering, Avionics Division, Romania
Victor EMANOIL	Aerospace Consulting, Romania
<b>F</b>	
Lavinia Gavrilă FLORESCU	National Institute for Lasers, Plasma and Radiation Physics, Laser Department
Florin FRUNZULICĂ	"Gheorghe Mihoc-Caius Iacob" Institute of Mathematical Statistics and Applied Mathematics of Romanian Academy, "POLITEHNICA" University of Bucharest e-mail: ffrunzi@yahoo.com
Ion FUIOREA	Institute for Theoretical and Experimental Analysis of Aeronautical Structures STRAERO, Bucharest e-mail: ifuiorea@straero.ro
<b>G</b>	
Mircea GĂVAN	"POLITEHNICA" University of Bucharest, Department of Strength of Materials, Laboratory for integrity evaluation of composite structures
Veta GHENESCU	Institute for Space Sciences, Magurele-Ilfov, Romania
Alexandru GHEORGHIU	Air Force Academy "Henri Coanda" Brasov e-mail: toranoko2003@yahoo.com
Andre GIOVANNINI	Institute of Fluid Mechanics Toulouse, France
Victor GIURGIUȚIU	University of South Carolina, Mechanical Engineering Dept., Columbia, SC, USA e-mail: giurgiut@engr.sc.edu
Teodor Lucian GRIGORIE	University of Craiova, Faculty of Electrical Engineering, Avionics Division, Romania e-mail: lgrigore@elth.ucv.ro
Gheorghe GUIMAN	Military Equipment and Technology Research Agency, Romania

**H**

Vladimir HORÁK  
University of Defence, Kounicova 65, Brno, Czech Republic  
e-mail: vladimir.horak@unob.cz

Gabriela HRISTEA  
National Institute of Electrical Engineering Researche-Advanced  
Researche (INCDIE-CA, Dep. MNE), Romania

**I**

Sorina IFTIMIE  
Department of Solid State Physics, University of Bucharest,  
Magurele-Ilfov, Romania  
e-mail: sorinaiftimie@yahoo.com

Mircea IGNAT  
National Institute of Electrical Engineering Researche-Advanced  
Researche (INCDIE-CA, Dep. MNE), Romania  
e-mail: mignat@icpe-ca.ro

Ioan ION  
Military Technical Academy, Romania

Lucian ION  
Department of Solid State Physics, University of Bucharest,  
Magurele-Ilfov, Romania

Georgeta IONAȘCU  
"POLITEHNICA" University of Bucharest

Gheorghe IONESCU  
INCAS - National Institute for Aerospace Research "Elie Carafoli",  
Romania  
e-mail: gheion@yahoo.com

Achim IONIȚĂ  
Institute for Theoretical and Experimental Analysis of Aeronautical  
Structures STRAERO, Bucharest  
e-mail: achim.ionita@straero.ro

Lucian IORGA  
now at Airbus UK  
e-mail: NICOLAE.IORGA@airbus.com

Sorin ISTOC  
MAGIC Engineering S.R.L., Brasov, Romania  
e-mail: sorin.istoc@magic-engineering.ro

Jean Louis IZBICKI  
National Institute for Research and Development in  
Microtechnologies, Romania

**K**

Miroslav KELEMEN  
Armed Forces Academy of General M. R. Štefánik, Demänová 393,  
031 01 Liptovský Mikuláš, Slovak Republic  
e-mail: miroslav.kelemen@aos.sk

**L**

Ion LĂNCRĂNAN  
Advanced Study Center–National Institute of Aerospace Research  
"Elie Carafoli"  
e-mail: ilancranjan@incas.ro

Lucia LEONAT  
National Institute for Research & Development in Electrical  
Engineering ICPE – Advanced Researches (INCDIE ICPE - CA)  
Multifunctional Metalic Materials Department, Romania

Irina Gabriela LOLU  
"POLITEHNICA" University of Bucharest, Romania, Automatic  
Control and Applied Informatics Department

Dorin LOZICI-BRÎNZEI	INCAS - National Institute for Aerospace Research "Elie Carafoli", Romania e-mail: lozicid@incas.ro
Mariana LUCACI	National Institute for Research & Development in Electrical Engineering ICPE – Advanced Researches (INCDIE ICPE - CA) Multifunctional Metallic Materials Department, Romania e-mail: lucaci@icpe-ca.ro
Emil LUNGU	Valahia University of Târgoviște
Mihai Aureliu LUNGU	University of Craiova, Avionics Department
<b>M</b>	
Victor MANOLIU	Aerospace Consulting, Romania e-mail: vmanoliu@yahoo.com, vmanoliu@incas.ro
Niculae MARIN	Aerospace Consulting, Romania e-mail: marin@incas.ro
Dan MATEESCU	Aerospace Program, Department of Mechanical Engineering McGill University, Montreal, Quebec, Canada H3A 2K6 e-mail: dan.mateescu@mcgill.ca
Gheorghe MATIȘ	Air Force Academy "Henri Coanda" Brasov, Romania e-mail: geo_matis@yahoo.com
Petru MAZĂRE	Military Equipment and Technologies Research Agency, Romania
Sorin MICLOȘ	INOE 2000, Romania
Matei Constantin MIRON	Department of Strength of Materials, "POLITEHNICA" University of Bucharest
Tudor Luca MITRAN	Department of Solid State Physics, University of Bucharest, Magurele-Ilfov, Romania
Laurian Tiberiu MOCANU	Aerostar SA Bacau, Romania e-mail: tiberiu.mocanu@aerostar.ro
Mihnea Alexandru MOISESCU	"POLITEHNICA" University of Bucharest, Romania, Automatic Control and Applied Informatics Department e-mail: mamihnea@gmail.com
Carmen MOLDOVAN	National Institute for Research and Development in Microtechnologies, Romania
Cristian-Emil MOLDOVEANU	Military Technical Academy Bucarest e-mail: mcristi@gmail.com
Laurențiu MORARU	"POLITEHNICA" University of Bucharest, Faculty of Aerospace Engineering, The "Elie Carafoli" Chair of Aerospace Sciences e-mail: laurentiu.moraru@gmail.com
Florin MUNTEANU	Aerospace Consulting, Romania e-mail: munteanu@incas.ro
Adrian MURARU	Air Force Academy "Henri Coanda" Brasov, Romania e-mail: muraruady@gmail.com

**N**

- Cătălin NAE  
INCAS - National Institute for Aerospace Research "Elie Carafoli",  
Romania  
e-mail: cnae@incas.ro
- Adriana NĂSTASE  
Aerodynamik des Fluges, RWTH - Aachen, Germany,  
Templergraben 55  
e-mail: nastase@lafaero.rwth-aachen.de
- Andrei-Sorin NEAMȚU  
INCAS - National Institute for Aerospace Research "Elie Carafoli",  
Romania  
e-mail: aneamtu@incas.ro
- Mihai NEAMȚU  
INCAS - National Institute for Aerospace Research "Elie Carafoli",  
Romania  
e-mail: neamtu@incas.ro
- Ștefan NEBANȚEA  
INCAS - National Institute for Aerospace Research "Elie Carafoli",  
Romania  
e-mail: nebancea@incas.ro
- Pavel NEČAS  
Armed Forces Academy of General M. R. Štefánik, Demánová 393,  
031 01 Liptovský Mikuláš, Slovak Republic  
e-mail: pavel.necas@aos.sk

**O**

- Radu OBREJA  
University of Craiova, Faculty of Electrical Engineering, Avionics  
Division, Romania
- Gheorghi OPAȚCHI  
"POLITEHNICA" University of Bucharest

**P**

- Cristina PACHIU  
National Institute for Research and Development in  
Microtechnologies, Romania  
e-mail: [cristina.pachiu@imt.ro](mailto:cristina.pachiu@imt.ro) ; [cristina.pachiu@gmail.com](mailto:cristina.pachiu@gmail.com)
- Anton PAL  
Aerostar SA Bacau, Romania  
e-mail: anton.pal@aerostar.ro
- Valentin PANĂ  
"POLITEHNICA" University of Bucharest  
e-mail: valentin\_pana@yahoo.com
- Petrișor Valentin PÂRVU  
"POLITEHNICA" University of Bucharest  
e-mail: [parvu@aero.pub.ro](mailto:parvu@aero.pub.ro)
- Delia PATROI  
National Institute for Research & Development in Electrical  
Engineering ICPE – Advanced Researches (INCDIE ICPE - CA)  
Multifunctional Metallic Materials Department, Romania
- Neculai PĂUN  
Flight Test Center (CCIZ), Craiova, Romania  
e-mail: paun@ftc.ro
- Horia PAVEN  
ICECHIM - National Institute for Research & Development in  
Chemistry and Petrochemistry
- Octavian Thor PLETER  
"POLITEHNICA" University of Bucharest  
e-mail: octavianpleter@yahoo.com



Alin POHOAȚĂ	Valahia University of Târgoviște e-mail: alinpohoata@yahoo.com
Ștefan POPA	Aerostar SA Bacau, Romania
Alin Gabriel POPESCU	Department of Computer Sciences, IT CORE SRL
Dumitru POPESCU	Department of Mathematical Modelling in Life Sciences, "Gheorghe Mihoc-Caius Iacob" Institute of Mathematical Statistics and Applied Mathematics of Romanian Academy e-mail: popescu1947@yahoo.com
Ionel POPESCU	Institute for Theoretical and Experimental Analysis of Aeronautical Structures STRAERO, Bucharest
Mihai POPESCU	"Gheorghe Mihoc-Caius Iacob" Institute of Mathematical Statistics and Applied Mathematics of Romanian Academy e-mail: ima_popescu@yahoo.com
Oana PORUMB	Department of Solid State Physics, University of Bucharest, Magurele-Ilfov, Romania
Octavian PREOTU	University of Craiova, Avionics Department e-mail: opreotu@yahoo.com, opreotu@elth.ucv.ro
Mihai Victor PRICOP	INCAS - National Institute for Aerospace Research "Elie Carafoli", Romania e-mail: vpricop@incas.ro
Ioan PUFLEA	National Institute of Electrical Engineering Research-Advanced Research (INCDIE-CA, Dep. MNE), Romania
<b>R</b>	
Sorin RADNEF	INCAS - National Institute for Aerospace Research "Elie Carafoli", Romania e-mail: sradnef@incas.ro
Ionuț RĂDOI	Military Equipment and Technologies Research Agency, Romania
Adrian RADU	Department of Solid State Physics, University of Bucharest, Magurele-Ilfov, Romania
Mihai RADU	Department of Solid State Physics, University of Bucharest, Magurele-Ilfov, Romania
Dorin ROȘU	Compozite SRL, Brasov, Romania e-mail: compozitebv@yahoo.com
Constantin ROTARU	Department of Aviation Integrated Systems, Military Technical Academy e-mail: crotaru@mta.ro
Ioan RUSU	Electrica Serv, SISE Muntenia Nord, Romania e-mail: ioandanrusu@yahoo.com
<b>S</b>	
Ioan Ștefan SACALA	"POLITEHNICA" University of Bucharest, Romania, Automatic Control and Applied Informatics Department e-mail: sacalaioan@yahoo.com
Doru SAFTA	Military Technical Academy, Romania e-mail: doru.safta@yahoo.com

Adriana SANDU	"POLITEHNICA" University of Bucharest e-mail: agsandu@yahoo.com
Constantin SANDU	SC Turbomecanica SA – Bucharest e-mail: Constantin.Sandu@turbomecanica.ro
Marin SANDU	Department of Strength of Materials, "POLITEHNICA" University of Bucharest e-mail: marin_sandu@yahoo.com
Dan SAVASTRU	INOE 2000, Romania
George SAVU	COMOTI National Research and Development Institute for Gas Turbines, Bucharest e-mail: george.savu@comoti.ro
Pamfil ȘOMOIAG	Military Technical Academy Bucharest
Ștefan SOROHAN	"POLITEHNICA" University of Bucharest, Department of Strength of Materials, Laboratory for integrity evaluation of composite structures e-mail: fanes777@yahoo.com
Pătru SPĂTARU	INCAS - National Institute for Aerospace Research "Elie Carafoli", Romania e-mail: pspataru@incas.ro
Iuliana SPRINȚU	Military Technical Academy, Institute for Theoretical & Experimental Analysis of Aeronautical Structure
Ana STAN	INCAS - National Institute for Aerospace Research "Elie Carafoli", Romania e-mail: anastan@incas.ro
Virgil STANCIU	"POLITEHNICA" University of Bucharest, Faculty of Aerospace Engineering e-mail: v_stanciu@aero.pub.ro vvirgilstanciu@yahoo.com
Aurelian Mihai STĂNESCU	"POLITEHNICA" University of Bucharest, Romania, Automatic Control and Applied Informatics Department e-mail: amstanescu@yahoo.com, ams@cpru.pub.ro
Adriana ȘTEFAN	INCAS - National Institute for Aerospace Research "Elie Carafoli", Romania e-mail: adriana@incas.ro, adriana_stefan@yahoo.com
Adrian-Mihail STOICA	"POLITEHNICA" University of Bucharest, Faculty of Aerospace Engineering e-mail: amstoica@rdslink.ro
Marcel STERE	Aerospace Consulting, Bucharest e-mail: sterem@incas.ro
Corneliu-Ioan STOICA	INCAS - National Institute for Aerospace Research "Elie Carafoli", Romania e-mail: wwwcornel@yahoo.com
Mădălina STOICA	Department of Strength of Materials, "POLITEHNICA" University of Bucharest
Gabriela Liliana STROE	POLITEHNICA" University of Bucharest, Faculty of Aerospace Engineering, Department "Elie Carafoli" of Aerospace Sciences, Department "Nicolae Tîpei" of Avionics

Ion STROE

"POLITEHNICA" University of Bucharest, Romania  
e-mail: ion.stroe@gmail.com

**T**

Gabriel TÂRȘA

Military Equipment and Technology Research Agency, Romania

Simion TĂTARU

Aerospace Consulting, Bucharest, Romania  
e-mail: sitataru@incas.ro

Cezar TAZLAOANU

Department of Solid State Physics, University of Bucharest,  
Magurele-Ilfov, Romania

George TECUCEANU

INCAS - National Institute for Aerospace Research "Elie Carafoli",  
Romania  
e-mail: gtecu@incas.ro

Peter TEREM

Matej Bel University, Kuzmányho 1, 974 01 Banská Bystrica, Slovak  
Republic  
e-mail: peter.terem@umb.sk

Loredana TERZEA

"POLITEHNICA" University of Bucharest

Adrian TOADER

INCAS - National Institute for Aerospace Research "Elie Carafoli",  
Romania  
e-mail: atoader@incas.ro

Octavian TRIFU

Ecole Polytechnique Montreal, Canada  
e-mail: octavian.trifu@sympatico.ca

Violeta TSAKIRIS

National Institute for Research & Development in Electrical  
Engineering ICPE – Advanced Researches (INCDIE ICPE - CA)  
Multifunctional Metallic Materials Department, Romania

**U**

Ioan URSU

INCAS - National Institute for Aerospace Research "Elie Carafoli",  
Romania  
e-mail: iursu@incas.ro

**V**

Titică VASILE

Military Technical Academy, Romania

Claudiu Cristian VĂDEAN

INCAS - National Institute for Aerospace Research "Elie Carafoli",  
Romania  
e-mail: claudiu.vadean@gmail.com

Constantin VÂLCU

COMOTI National Research and Development Institute for Gas  
Turbines, Bucharest  
e-mail: constantin.valcu@comoti.ro

Florin VLĂDULESCU

SC INAS SA Craiova, Romania  
e-mail: florinv@inas.ro

## Authors Index

### A

Maria ALEXANDRESCU, 10  
Nicușor ALEXANDRESCU, 10  
Irina Carmen ANDREI, 604  
Maria ANDRONIE, 559, 564  
Mihai ANDRONIE, 559, 564  
Viorel ANGHEL, 267  
Ștefan ANTOHE, 330  
Vlad Andrei ANTOHE, 330  
Dragoș Alexandru APOSTOL, 272  
Nicolae APOSTOLESCU, 285

### B

Agneta M. BALINT, 407  
Ștefan BALINT, 407  
Alexandru Tristian BALMUȘ, 446  
Aurelian Virgil BALUȚĂ, 568  
Daniela BARAN, 285, 293  
Corneliu BERBENTE, 19  
Sorin BERBENTE, 19  
Cristina BEȘLEAGĂ, 330  
Radu BÎSCĂ, 279  
Mircea BOCIOAGĂ, 301  
Radu BOGĂȚEANU, 80, 553  
Ștefan BOGOS, 39  
Henri-Claude BOISSON, 121  
Dionezie BOJIN, 381  
Andreea BORÎTU, 267  
Mircea BOȘCOIANU, 176  
Adina Otilia BOTEANU, 308  
Dan BRAȘOVEANU, 213, 224  
Marius BREBENEL, 27  
Gigi-Daniel BUDARIU, 438  
Valentin BUTOESCU, 47

### C

Bogdan CALOIAN, 279  
Adrian CARABINEANU, 59, 134  
Vladimir CARDOȘ, 80, 90

Laurențiu CĂTĂNESCU, 325  
Mircea Dimitrie CAZACU, 316  
Zdeněk CHÁRA, 97  
Adrian CHELARU, 412  
Teodor-Viorel CHELARU, 412  
Constantin CIOLOFAN, 397  
Marius Gabriel COJOCARU, 70  
Nicolae CONSTANTIN, 267  
Dan Mihai CONSTANTINESCU, 272  
Andrei CRĂIFĂLEANU, 47  
Ștefan Gicu CRUCEANU, 59

### D

Sterian DĂNĂILĂ, 19  
Mirela DARAU, 407  
Alin George DIACONU, 496  
Sorin DIMITRIU, 381  
Ion DINCĂ, 372  
Sorin DINEA, 171  
Claudia DOBRE, 576  
Bogdan DONCIU, 420  
Alexandru DUMITRACHE, 90, 201  
Ioan DUMITRACHE, 594  
Liviu DUMITRACHE, 372  
Adrian DUMITRESCU, 446  
Horia DUMITRESCU, 80, 90  
Eugen DUMITRU, 511

### E

Ioana Raluca EDU, 428  
Victor EMANOIL, 591

### F

Lavinia GAVRILĂ FLORESCU, 372  
Florin FRUNZULICĂ, 90, 171  
Ion FUIOREA, 365

### G

Mircea GĂVAN, 267  
Veta GHENESCU, 330  
Alexandru GHEORGHIU, 176

Andre GIOVANNINI, 121  
Victor GIURGIUȚIU, 251  
Teodor Lucian GRIGORIE, 428  
Gheorghe GUIMAN, 438

**H**

Vladimir HORÁK, 97  
Gabriela HRISTEA, 318

**I**

Sorina IFTIMIE, 330  
Mircea IGNAT, 318, 325  
Ioan ION, 529  
Lucian ION, 330  
Georgeta IONAȘCU, 539  
Gheorghe IONESCU, 381  
Achim IONIȚĂ, 182  
Lucian IORGA, 471  
Sorin ISTOC, 341  
Jean Louis IZBICKI, 350

**K**

Miroslav KELEMEN, 579

**L**

Ion LĂNCRĂNJAN, 515  
Lucia LEONAT, 343  
Irina Gabriela LOLU, 594  
Dorin LOZICI-BRÎNZEI, 293, 591  
Mariana LUCACI, 343  
Emil LUNGU, 134  
Mihai Aureliu LUNGU, 201, 428

**M**

Victor MANOLIU, 381  
Niculae MARIN, 165, 412, 545  
Dan MATEESCU, 105  
Gheorghe MATIȘ, 583  
Petru MAZĂRE, 308  
Sorin MICLOȘ, 515  
Matei Constantin MIRON, 272  
Tudor Luca MITRAN, 330  
Laurian Tiberiu MOCANU, 446  
Mihnea Alexandru MOISESCU, 594

Carmen MOLDOVAN, 350  
Cristian-Emil MOLDOVEANU, 121  
Laurențiu MORARU, 504  
Florin MUNTEANU, 545  
Adrian MURARU, 583

**N**

Cătălin NAE, 127  
Adriana NASTASE, 3  
Andrei-Sorin NEAMȚU, 487  
Mihai NEAMȚU, 157  
Ștefan NEBANȚEA, 47, 157  
Pavel NEČAS, 579

**O**

Radu OBREJA, 428  
Gheorghe OPAȚCHI, 357

**P**

Cristina PACHIU, 350  
Anton PAL, 446  
Valentin PANĂ, 456  
Petrișor Valentin PÂRVU, 241  
Delia PATROI, 343  
Neculai PĂUN, 196  
Horia PAVEN, 372  
Octavian Thor PLETER, 420, 496  
Alin POHOAȚĂ, 134  
Ștefan POPA, 446  
Alin Gabriel POPESCU, 140  
Dumitru POPESCU, 140  
Ionel POPESCU, 182  
Mihai POPESCU, 463  
Oana PORUMB, 330  
Octavian PREOTU, 201  
Mihai Victor PRICOP, 165  
Ioan PUFLEA, 318, 325

**R**

Sorin RADNEF, 182, 591  
Ionuț RĂDOI, 438  
Adrian RADU, 330  
Mihai RADU, 330  
Dorin ROȘU, 272

Constantin ROTARU, 149

Ioan RUSU, 524

**S**

Ioan Ștefan SACALA, 594

Doru SAFTA, 529

Adriana SANDU, 357, 539

Constantin SANDU, 213, 224

Marin SANDU, 272, 357, 539

Dan SAVASTRU, 515

George SAVU, 232

Pamfil ȘOMOIAG, 121

Ștefan SOROHAN, 267

Pătru SPĂȚARU, 545

Iuliana SPRINȚU, 365

Ana STAN, 372

Virgil STANCIU, 496, 604

Aurelian Mihai STĂNESCU, 594

Adriana ȘTEFAN, 372, 381

Adrian-Mihail STOICA, 487

Marcel STERE, 391

Corneliu-Ioan STOICA, 553

Mădălina STOICA, 272

Gabriela Liliana STROE, 604

Ion STROE, 241

**T**

Gabriel TÂRȘA, 438

Simion TĂȚARU, 293

Cezar TAZLĂOANU, 330

George TECUCEANU, 471

Peter TEREM, 579

Loredana TERZEA, 357

Adrian TOADER, 471

Octavian TRIFU, 232

Violeta TSAKIRIS, 343

**U**

Ioan URSU, 471

**V**

Titică VASILE, 529

Claudiu Cristian VĂDEAN, 70

Conaștin VĂLCU, 381

Florin VLĂDULESCU, 397

**Proceedings**  
**of the International Conference of Aerospace Sciences**  
**“AEROSPATIAL 2010”**  
**20 - 21 October, 2010**  
**Bucharest, Romania**

*Organizers:*

**INCAS - National Institute for Aerospace Research "Elie Carafoli"**  
(under the aegis of The Romanian Academy)

*In collaboration with:*  
**The Ministry of Education, Research, Youth and Sport**

**SCIENTIFIC COMMITTEE**

PhD Eng. Cătălin NAE  
PhD Eng. Sorin RADNEF  
PhD Eng. Cornel OPRIȘIU  
PhD Eng. Dan PANTAZOPOL  
PhD Eng. Mihai NEAMȚU  
PhD Eng. Florin MUNTEANU  
PhD Eng. Marcel STERE  
PhD Math. Daniela BARAN  
PhD Eng. Richard ȘELESCU  
PhD Eng. Valentin BUTOESCU  
PhD Math. Ioan URSU  
PhD Eng. Victor MANOLIU  
PhD Eng. Nicolae MARIN

**ORGANIZING COMMITTEE**

Eng. Simion TĂTARU  
PhD student Eng. Dorin LOZICI BRÎNZEI  
PhD student Eng. Radu BOGĂȚEANU  
PhD student Eng. Victor PRICOP  
Eng. Claudia DOBRE  
Eng. Emil COSTEA  
Eng. Andreea BOBONEA  
English translator: Lavinia BOSILCĂ  
Legal advisor Alina MARCU  
Network Adm. Cristian GRIGORESCU  
Webmaster and editing: Elena NEBANCEA

**SECRETARIAL STAFF**

Tech. Daniela NICULESCU  
Tech. Elena DRAGOMAN

**ISSN 2067 - 8614**  
**ISSN National Center**  
**Romanian National Library**

**BUCHAREST**  
**2010**